SINPAR®

CATÁLOGO

**DE FRESAS DE METAL DURO INTEGRAL Y ACERO RÁPIDO,
BROCAS Y HERRAMIENTAS ESPECIALES**





UNA HISTORIA DE CRECIMIENTO E INNOVACIÓN CONSTANTE

Fundada en 1931, **SIN PAR** se ha posicionado como una de las empresas argentinas referentes en soluciones tecnológicas para procesos de corte y mecanizado. Cuenta con cientos de clientes en múltiples segmentos de industrias, fabricantes, distribuidores mayoristas, ferreterías, frigoríficos, talleres mecánicos, carnicerías y consumidores finales.

SIN PAR es reconocida por la producción y comercialización de todo el espectro imaginable de hojas de sierra y cuchillas industriales, pero también por su amplio programa de herramientas de corte y mecanizado, accesorios para usuarios de máquinas-herramienta, máquinas de cinta sin fin, tornos CNC, centros de mecanizado y servicios de reparación y capacitación.

La constante innovación, con foco en la calidad y soluciones eficaces de alto rendimiento, han sido guía para **SIN PAR** a la hora de actualizar sus productos e incorporar las más recientes tecnologías, mediante inversiones en equipamientos CNC, sistemas robotizados e instrumentos de medición y control de alta precisión.

En los últimos años, **SIN PAR** ha ampliado su propuesta de valor, con una oferta de mayor complejidad y tecnología. Además, la empresa ha incorporado a su abanico de servicios distintas instancias de capacitación, entrenamientos, demostraciones y cursos in-company orientados a sus clientes y el sector en general.

Gracias a la experiencia de su equipo de trabajo y referentes, la oferta de productos **SIN PAR** se complementa con distintas instancias de intercambio de conocimiento con el sector, asesoría y servicios en sintonía con las premisas de profesionalismo, cercanía, confianza y mejora continua.

GARANTÍA DE CALIDAD

Décadas de liderazgo en permanente evolución se han apoyado en una clara línea de negocios de **SIN PAR**, orientada a las necesidades de los clientes y el mercado en general. Para cumplir con esas expectativas la empresa se ha alineado con las pautas de un Sistema de Gestión Integrado, certificado según las normas ISO 9001, ISO 14001 e ISO 50001 y el estándar OHSAS 18001.



NUESTRO COMPROMISO DE SIEMPRE

Cuando miramos hacia atrás, repasamos nuestra trayectoria, nos encontramos con muchas historias de distintas generaciones, personas e incluso familias que han contribuido de una u otra manera al desarrollo de **SIN PAR**. Nos pasa lo mismo cuando proyectamos a futuro: convencidos del valor de cada una de esas caras, de esos nombres y esas historias que seguirán nutriendo a la empresa en los años por venir.

Son parte del equipo en nuestras plantas y oficinas, nuestros clientes en distintos puntos del país, estudiantes y becarios, también los socios comerciales con quienes aunamos esfuerzos. Personas e historias con quienes año a año ratificamos a **SIN PAR** como un espacio de puertas abiertas para conocer y sumarse a esta búsqueda de permanente innovación en la industria del corte y mecanizado.

Nunca nos quedamos quietos. Elegimos que la confianza y la honestidad sean el sustento de una constante búsqueda orientada a las necesidades de nuestros clientes. Porque tenemos que crecer a la par. Por eso nos animamos a crear nuevos productos e incursionar en distintos rubros.

En esos valores, en la experiencia y los conocimientos que compartimos, encontramos la principal fortaleza para apuntalar la excelencia en la propuesta de valor de **SIN PAR**. Calidad, alto rendimiento, tecnología de punta y mejora continua; nada de esto sería posible, sin esas personas y sus trayectorias, el aporte que todos los días hacen al sector.

A lo largo de los años, en **SIN PAR** hemos logrado certificaciones de calidad, y nos han honrado con premios y distinciones. Sean sobre responsabilidad social empresaria, el cuidado del medio ambiente u otros, son reconocimientos a nuestro mayor compromiso: todas esas personas que nos acompañan día a día.

Estamos orgullosos de esos recorridos enlazados con la trayectoria de **SIN PAR**. Lo asumimos así cuando repasamos nuestra historia, pero sobre todo cuando miramos hacia adelante. Orgullosos de lo que somos y de todo lo que podemos ser.



Ing. Manfredo Arbeit

PRESIDENTE
SIN PAR S.A.

ÍNDICE

Tabla de selección

07

Fresas de metal duro integral

	Forma de la punta	Filos	Página
	Planas	2	11
	Planas	3	13
	Planas	4	15
	Planas antivibratorias	3	17
	Planas hélice variable	4	18
	Planas combinadas (desbaste + terminación)	4	19
	Planas para contorneado	4	20
	Esféricas	2	21
	Esféricas	3	23
	Esféricas	4	25

ÍNDICE

Fresas de metal duro integral

	Forma de la punta	Filos	Página
	Esféricas copiado	2	27
	Tóricas	4	28
	Radio cóncavo	4	30
	Para achaflanado	4 y 6	31
	Para router upcut	1 y 2	32
	Para router downcut	1 y 2	33
	Para router hélices opuesta	2	34
	De canales rectos	2	35
	Para copiado, Superfinish	2	36
	Para grabado	2	37
	Microfresas	2, 3 y 4	38
	Microfresa descarga "R"	2	39
	Perfil circular	3 y 4	40

ÍNDICE

	Forma de la punta	Filos	Página
Brocas		Para Chapista	42
		Para centrar NC	42
Fresas de acero rápido		Planas DIN 327	2 44
		Planas DIN 844	4 45
		Fresolines HSS -Co	46
Pinzas ER		Pinzas ER	48
Herramientas Especiales		Cuchillas para router	50
		Fresas especiales a pedido	51
		Servicio de reafilado	51

TABLA DE SELECCIÓN, FRESAS PARA USO GENERAL















	pag 11	pag 13	pag 15 y 20	pag 18	pag 21	pag 23	pag 25	
								
								
FORMA DE LA PUNTA	PLANA (FRONTAL)				ESFÉRICA			
TIPO	N	N	N	N	N	N	N	
CANTIDAD DE FILOS	2	3	4	4	2	3	4	
ÁNGULO DE HELICE	30°	30°	30°	41° / 44°	30°	30°	30°	
ÁNGULO DE ATAQUE	7°	7°	7°	7°	7°	7°	7°	
CALIDAD DEL METAL DURO	MICROGRANO							

TABLA DE SELECCIÓN

FAMILIA	MATERIAL	Rm/UTS (N/mm ²)	EJEMPLO										
			FORMA DE LA PUNTA			PLANA (FRONTAL)				ESFÉRICA			
			TIPO			N	N	N	N	N	N	N	N
			CANTIDAD DE FILOS			2	3	4	4	2	3	4	4
			ÁNGULO DE HELICE			30°	30°	30°	41°/44°	30°	30°	30°	30°
			ÁNGULO DE ATAQUE			7°	7°	2°	7°	7°	7°	7°	7°
			CALIDAD DEL METAL DURO			MICROGRANO							
P	DESCRIPCIÓN	DIN	AISI										
				ACERO DE CONSTRUCCIÓN NO ALEADO	-700	St 52	1.0052	1010	●	●	●	●	●
ACERO DE FÁCIL MECANIZADO	-700	9 SMn 28	1.0715	1213	●	●	●	●	●	●	●		
ACERO DE CONSTRUCCIÓN	500-950	Ck 45	1.1191	C1045	●	●	●	●	●	●	●		
		26 CrMo4	1.7219	4132		●	●	●					
ACERO BONIFICADO, RESISTENCIA MEDIA	500-950	42 CrMo4	1.7225	4140	●	●	●	●	●	●	●		
		50CrV4	1.2241	6150	●	●	●	●					
ACERO FUNDIDO	-950	GS40	1.0416	1020	●	●	●	●	●	●	●		
ACERO DE CEMENTACIÓN	-950	16 MnCr 5	1.7131	5115/5117	●	●	●	●	●	●	●		
ACERO INOXIDABLE Y RESISTENTE A LOS ÁCIDOS, FERRÍTICO, MARTENSÍTICO	500-950	X 10 Cr 13	1.4006	410	●	●	●	●	○	●	●		
		X 12 CrMoS 17	1.4104	430F	●	●	●	●					
		X 35 CrMo 17	1.4122	440	●	●	●	●					
ACERO BONIFICADO, RESISTENCIA ALTA	950-1400	42 CrMo 4	1.7225	4140H	●	●	●	●	●	●	●		
		30 CrNiMo 8	1.6580	4340	●	●	●	●					
ACERO PARA NITRURAR, BONIFICADO	950-1400	34 CrAl 6	1.8504	--	●	●	●	●	●	○	○		
ACERO PARA HERRAMIENTAS	950-1400	X 38 CrMoV 5 1	1.2343	H11	●	●	●	●	●	○	○		
		X 155 CrVMo 12 1	1.2379	D2	●	●	●	●					
M	ACERO INOXIDABLE Y RESISTENTE A LOS ÁCIDOS, AUSTENÍTICO	500-950	X 5 CrNi 18 10	1.4307	304L	UTILIZABLES PARA OPERACIÓN DE TERMINACIÓN			●	○	○	○	
			X 10 CrNiMo 18 10	1.4571	316Ti				●				
	ACERO MARTENSÍTICO TEMPLABLE		X 3 NiCoMoTi 18 9 5	1.2709	--			○	●	○	○	○	
K	FUNDICIÓN GRIS	-550	GG25	0.6025	ASTM A48		●	●	●	○	●	●	
	FUNDICIÓN GRIS ALEADA	300-700	GGL-NiCr 35 2	0.6678	ASTM A532	●	●	●	●	○	●	●	
	FUNDICIÓN ESFEROIDAL	-500	GGG60	0.7060	ASTM A536	●	●	●	●	○	●	●	
	FUNDICIÓN MALEABLE	40-70	GTS55	0.8155	ASTM A439	●	●	●	●	○	●	●	

● Muy adecuado ○ También utilizable

FAMILIA	MATERIAL	Rm/UTS (N/mm ²)	EJEMPLO										
				FORMA DE LA PUNTA			PLANA (FRONTAL)		ESFÉRICA				
				TIPO			N	N	N	N	N	N	
				CANTIDAD DE FILOS			2	3	4	4	2	3	4
				ÁNGULO DE HELICE			30°	30°	30°	41°/44°	30°	30°	30°
				ÁNGULO DE ATAQUE			7°	7°	2°	7°	7°	7°	7°
				CALIDAD DEL METAL DURO			MICROGRANO						
DESCRIPCIÓN	DIN	AISI											
N	METALES PUROS, BLANDOS	400-800 (120-310 HB)	Hierro puro, plomo	1.1003	PLOMO	○	○	○	○	○	●	●	
	ALEACIONES DE ALUMINIO, DE VIRUTA LARGA	100-400 (120-310 HB)	AlMg 3	3.3535	EN AW 5754	○	○	○	○	○	●	●	
			AlZnMgCu 1,5	3.4365	EN AW 7075	○	○	○	○	○	○	○	
	ALEACIONES DE ALUMINIO, DE VIRUTA CORTA	-400	G-AISI 12	3.2581	G-AISI 12	○	○	○	○	○	●	●	
	ALEACIONES DE COBRE, DE VIRUTA LARGA	150-250 (160-230 HB)	MS63	2.0320	Latón 63	○	○	○	○	○	○	●	●
			CuAl10Ni	2.0975	AFNOR U-A 10 N	○	○	○	○	○	○	○	○
	ALEACIONES DE COBRE, DE VIRUTA CORTA	-500	MS58	2.0402	Latón 58	○	○	○	○	○	○	●	●
	ALEACIONES DE MAGNESIO	160-300	G-MgAl9Zn1	3.5912	Magnesio Az 91 D	○	○	○	○	○	○	●	●
TERMOPLÁSTICOS	300-700 (150-280 HB)	PVC, vidrio acrílico			○	○	○		○	○	●	●	
DUROPLÁSTICOS	20-40	Baquelita, melamina	1.1191	C1045	○	○	○				●	●	
S	GRAFITO		Grafito	R8510	Grafito					○			
	ALEACIONES DE TITANIO, RESISTENCIA MEDIA	-950	TiAl5Sn2,5	3.7115	ASTM serie grado 6	○	○	○	●	○	○	○	
			TiAl6V4	3.7165	ASTM B265	○	○	○	●				
	ALEACIONES DE TITANIO, RESISTENCIA ALTA	900-1400	TiAl6Sn2	3.7174	AMS 4971/ 4978	○	○	○	●	○	○	○	
	ALEACIONES DE NÍQUEL, RESISTENCIA MEDIA	-950	NiCr12Al6MoNb	2.4670	Aleación 713 LC Inconel 713	○	○	○	●	○	○	○	
ALEACIONES DE NÍQUEL, ALTA RESISTENCIA AL CALOR	900-1400	NiCr19Fe19NbMo Inconel 718		ASTM B637/ B670	○	○	○	●		○	○		
H	FUNDICIÓN DURA	300-600	Ni-hard, Ampco	Ampco 25	Ampco 25	●	●	●	●		○	○	
	ACERO TEMPLADO	45-52 HRC 53-59 HRC				○	○	●	●		○	○	

● Muy adecuado ○ También utilizable

FRESAS

DE METAL DURO INTEGRAL

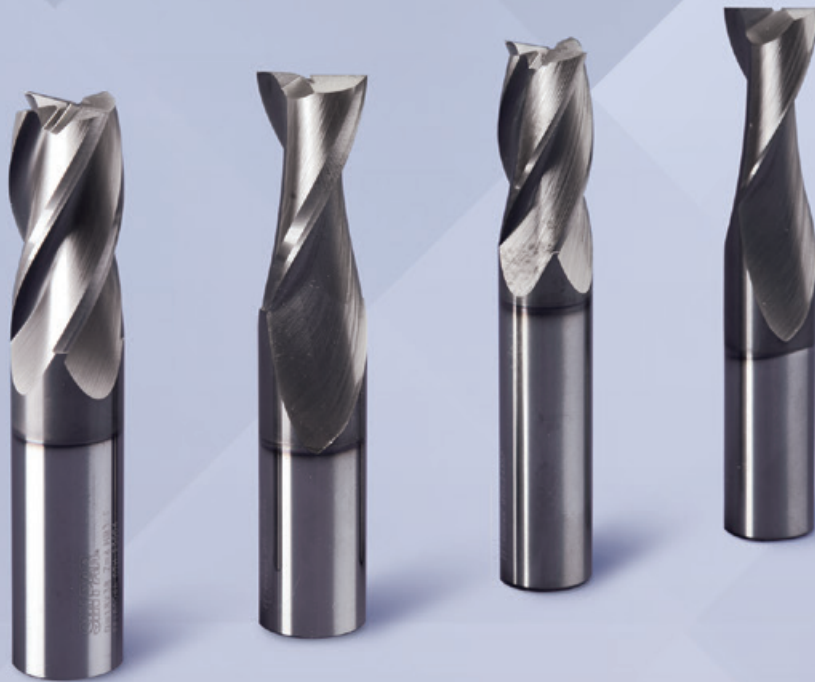

FRESAS PLANAS

FRONTALES, CON 2 FILOS

CARACTERÍSTICAS	
FORMA DE LA PUNTA	PLANA
TIPO	N
NORMA	DIN 6527 A
CANTIDAD DE FILOS	Z = 2
ÁNGULO DE HÉLICE	$\lambda = 30^\circ$
PASO	CONSTANTE
SENTIDO DE CORTE	DERECHO
FRENTE	CORTE AL CENTRO
TIPO DE MANGO	CILÍNDRICO SEGÚN DIN 6535 HA
LARGO DEL MANGO	SEGÚN TABLA
TOLERANCIA DEL MANGO	h6
TOLERANCIA DE LOS FILOS	h10
CALIDAD DEL METAL DURO	MICROGRANO
RECUBRIMIENTO	R302

▶ 2 FILOS

TIPOS DE MANGO: XC: EXTRA CORTO L: LARGO SIN REFERECIA: LARGO ESTANDAR (CORTO)

▶ CÓDIGO	▶ DESCRIPCIÓN				▶ FILOS	▶ DISPONIBILIDAD	▶ ENVASE
	▶ d ₁ mm	▶ d ₂ mm	▶ l ₁ mm	▶ l ₂ mm			
FRMD-FP01002A-XC	1,0	3	38	4	2	●	1 u
FRMD-FP01502A-XC	1,5	3	38	4,5	2	●	1 u
FRMD-FP02002A-XC	2,0	3	38	6	2	●	1 u
FRMD-FP02502A-XC	2,5	3	38	9,5	2	●	1 u
FRMD-FP03002A	3,0	3	50	12	2	●	1 u
FRMD-FP03002A-L	3,0	3	50	12	2	●	1 u
FRMD-FP03002A-XC	3,0	3	38	12	2	●	1 u
FRMD-FP03502A	3,5	4	50	12	2	●	1 u
FRMD-FP03502A-L	3,5	4	50	12	2	●	1 u
FRMD-FP04002A	4,0	4	50	14	2	●	1 u
FRMD-FP04002A-L	4,0	4	50	14	2	●	1 u
FRMD-FP04502A	4,5	5	50	16	2	●	1 u
FRMD-FP04502A-L	4,5	5	50	16	2	●	1 u
FRMD-FP05002A	5,0	5	50	16	2	●	1 u
FRMD-FP05002A-L	5,0	5	50	16	2	●	1 u
FRMD-FP06002A	6,0	6	57	19	2	●	1 u
FRMD-FP06002A-L	6,0	6	57	19	2	●	1 u
FRMD-FP07002A	7,0	7	63	19	2	●	1 u
FRMD-FP07002A-L	7,0	7	63	19	2	●	1 u
FRMD-FP08002A	8,0	8	63	20	2	●	1 u
FRMD-FP08002A-L	8,0	8	63	20	2	●	1 u

● Producto estándar en stock ○ Producto estándar a pedido ○ Producto especial a pedido

FRESAS PLANAS

FRONTALES, CON 2 FILOS

CÓDIGO	DESCRIPCIÓN				FILOS	DISPONIBILIDAD	ENVASE
	d ₁ mm	d ₂ mm	l ₁ mm	l ₂ mm			
FRMD-FP09002A	9,0	9	80	22	2	●	1 u
FRMD-FP09002A-L	9,0	9	80	22	2	●	1 u
FRMD-FP10002A	10,0	10	72	22	2	●	1 u
FRMD-FP10002A-L	10,0	10	72	22	2	●	1 u
FRMD-FP11002A	11,0	11	80	26	2	●	1 u
FRMD-FP11002A-L	11,0	11	80	26	2	●	1 u
FRMD-FP12002A	12,0	12	83	26	2	●	1 u
FRMD-FP12002A-L	12,0	12	83	26	2	●	1 u
FRMD-FP13002A	13,0	13	80	26	2	●	1 u
FRMD-FP13002A-L	13,0	13	80	26	2	●	1 u
FRMD-FP14002A	14,0	14	83	32	2	●	1 u
FRMD-FP14002A-L	14,0	14	83	32	2	●	1 u
FRMD-FP15002A	15,0	15	92	32	2	●	1 u
FRMD-FP16002A	16,0	16	92	32	2	●	1 u
FRMD-FP16002A-L	16,0	16	92	32	2	●	1 u
FRMD-FP17002A	17,0	17	92	38	2	●	1 u
FRMD-FP18002A	18,0	18	92	38	2	●	1 u
FRMD-FP18002A-L	18,0	18	92	38	2	●	1 u
FRMD-FP20002A	20,0	20	104	38	2	●	1 u
FRMD-FP20002A-L	20,0	20	104	38	2	●	1 u
FRMD-FP22002A	22,0	22	104	38	2	●	1 u
FRMD-FP22002A-L	22,0	22	104	38	2	●	1 u
FRMD-FP25002A	25,0	25	121	45	2	●	1 u
FRMD-FP25002A-L	25,0	25	121	45	2	●	1 u

● Producto estándar en stock ● Producto estándar a pedido ○ Producto especial a pedido

FRESAS PLANAS

FRONTALES, CON 3 FILOS

CARACTERÍSTICAS	
FORMA DE LA PUNTA	PLANA
TIPO	N
NORMA	DIN 6527 A
CANTIDAD DE FILOS	Z = 3
ÁNGULO DE HÉLICE	$\lambda = 30^\circ$
PASO	CONSTANTE
SENTIDO DE CORTE	DERECHO
FRENTE	CORTE AL CENTRO
TIPO DE MANGO	CILÍNDRICO SEGÚN DIN 6535 HA
LARGO DEL MANGO	SEGÚN TABLA
TOLERANCIA DEL MANGO	h6
TOLERANCIA DE LOS FILOS	h10
CALIDAD DEL METAL DURO	MICROGRANO
RECUBRIMIENTO	R302

▶ 3 FILOS

TIPOS DE MANGO: XC: EXTRA CORTO L: LARGO SIN REFERECIA: LARGO ESTANDAR (CORTO)

CÓDIGO	DESCRIPCIÓN				FILOS	DISPONIBILIDAD	ENVASE
	d ₁ mm	d ₂ mm	l ₁ mm	l ₂ mm			
FRMD-FP03003A	3,0	3	50	12	3	●	1 u
FRMD-FP03003A-L	3,0	3	50	12	3	●	1 u
FRMD-FP03003A-XC	3,0	3	38	12	3	●	1 u
FRMD-FP03503A	3,5	4	50	12	3	●	1 u
FRMD-FP03503A-L	3,5	4	50	12	3	●	1 u
FRMD-FP04003A	4,0	4	50	14	3	●	1 u
FRMD-FP04003A-L	4,0	4	50	14	3	●	1 u
FRMD-FP04503A	4,5	5	50	16	3	●	1 u
FRMD-FP04503A-L	4,5	5	50	16	3	●	1 u
FRMD-FP05003A	5,0	5	50	16	3	●	1 u
FRMD-FP05003A-L	5,0	5	50	16	3	●	1 u
FRMD-FP06003A	6,0	6	57	19	3	●	1 u
FRMD-FP06003A-L	6,0	6	57	19	3	●	1 u
FRMD-FP07003A	7,0	7	63	19	3	●	1 u
FRMD-FP07003A-L	7,0	7	63	19	3	●	1 u
FRMD-FP07503A-L	7,5	8	63	20	3	●	1 u
FRMD-FP08003A	8,0	8	63	20	3	●	1 u
FRMD-FP08003A-L	8,0	8	63	20	3	●	1 u
FRMD-FP09003A	9,0	9	80	22	3	●	1 u
FRMD-FP09003A-L	9,0	9	80	22	3	●	1 u
FRMD-FP10003A	10,0	10	72	22	3	●	1 u

● Producto estándar en stock ● Producto estándar a pedido ○ Producto especial a pedido

FRESAS PLANAS

FRONTALES, CON 3 FILOS

CÓDIGO	DESCRIPCIÓN				FILOS	DISPONIBILIDAD	ENVASE
	d ₁ mm	d ₂ mm	l ₁ mm	l ₂ mm			
FRMD-FP10003A-L	10,0	10	72	22	3	●	1 u
FRMD-FP11003A	11,0	11	80	26	3	●	1 u
FRMD-FP11003A-L	11,0	11	80	26	3	●	1 u
FRMD-FP12003A	12,0	12	83	26	3	●	1 u
FRMD-FP12003A-L	12,0	12	83	26	3	●	1 u
FRMD-FP12503A-L	12,5	13	83	26	3	●	1 u
FRMD-FP13003A	13,0	13	80	26	3	●	1 u
FRMD-FP13003A-L	13,0	13	80	26	3	●	1 u
FRMD-FP14003A	14,0	14	83	32	3	●	1 u
FRMD-FP14003A-L	14,0	14	83	32	3	●	1 u
FRMD-FP16003A	16,0	16	92	32	3	●	1 u
FRMD-FP16003A-L	16,0	16	92	32	3	●	1 u
FRMD-FP18003A	18,0	18	92	38	3	●	1 u
FRMD-FP18003A-L	18,0	18	92	38	3	●	1 u
FRMD-FP20003A	20,0	20	104	38	3	●	1 u
FRMD-FP20003A-L	20,0	20	104	38	3	●	1 u
FRMD-FP22003A	22,0	22	104	38	3	●	1 u
FRMD-FP22003A-L	22,0	22	104	38	3	●	1 u
FRMD-FP25003A	25,0	25	121	45	3	●	1 u
FRMD-FP25003A-L	25,0	25	121	45	3	●	1 u

● Producto estándar en stock ● Producto estándar a pedido ○ Producto especial a pedido

FRESAS PLANAS

FRONTALES, CON 4 FILOS

CARACTERÍSTICAS	
FORMA DE LA PUNTA	PLANA
TIPO	N
NORMA	DIN 6527 A
CANTIDAD DE FILOS	Z = 4
ÁNGULO DE HÉLICE	$\lambda = 30^\circ$
PASO	CONSTANTE
SENTIDO DE CORTE	DERECHO
FRENTE	CORTE AL CENTRO
TIPO DE MANGO	CILÍNDRICO SEGÚN DIN 6535 HA
LARGO DEL MANGO	SEGÚN TABLA
TOLERANCIA DEL MANGO	h6
TOLERANCIA DE LOS FILOS	h10
CALIDAD DEL METAL DURO	MICROGRANO
RECUBRIMIENTO	R302

▶ 4 FILOS

TIPOS DE MANGO: XC: EXTRA CORTO L: LARGO SIN REFERECIA: LARGO ESTANDAR (CORTO)

CÓDIGO	DESCRIPCIÓN				FILOS	DISPONIBILIDAD	ENVASE
	d ₁ mm	d ₂ mm	l ₁ mm	l ₂ mm			
FRMD-FP01004A-XC	1,0	3	38	4	4	●	1 u
FRMD-FP01004A-MR	1,0	4	50	3	4	●	1 u
FRMD-FP01504A-XC	1,5	3	38	4,5	4	●	1 u
FRMD-FP01504A-MR	1,5	4	50	5	4	●	1 u
FRMD-FP02004A-XC	2,0	3	38	6	4	●	1 u
FRMD-FP02004A-MR	2,0	4	50	6	4	●	1 u
FRMD-FP025004A	2,5	3	50	9,5	4	●	1 u
FRMD-FP025004A-XC	2,5	3	38	9,5	4	●	1 u
FRMD-FP02504A-MR	2,5	4	50	8	4	●	1 u
FRMD-FP03004A	3,0	3	50	12	4	●	1 u
FRMD-FP03004A-L	3,0	3	75	25	4	●	1 u
FRMD-FP03004A-XC	3,0	3	38	12	4	●	1 u
FRMD-FP03004A-MR	3,0	4	50	9	4	●	1 u
FRMD-FP03504A	3,5	4	50	14	4	●	1 u
FRMD-FP03504A-L	3,5	4	75	25	4	●	1 u
FRMD-FP04004A	4,0	4	50	14	4	●	1 u
FRMD-FP04004A-L	4,0	4	75	25	4	●	1 u
FRMD-FP04504A	4,5	5	50	16	4	●	1 u
FRMD-FP04504A-L	4,5	5	75	25	4	●	1 u
FRMD-FP05004A	5,0	5	50	16	4	●	1 u
FRMD-FP05004A-L	5,0	5	75	25	4	●	1 u
FRMD-FP05504A	5,5	6	57	19	4	●	1 u
FRMD-FP06004A	6,0	6	57	19	4	●	1 u
FRMD-FP06004A-L	6,0	6	75	25	4	●	1 u
FRMD-FP06004A-XL	6,0	6	100	30	4	●	1 u
FRMD-FP06504A	6,5	7	63	19	4	●	1 u

● Producto estándar en stock ● Producto estándar a pedido ○ Producto especial a pedido

FRESAS PLANAS

FRONTALES, CON 4 FILOS

CÓDIGO	DESCRIPCIÓN				FILOS	DISPONIBILIDAD	ENVASE
	d ₁ mm	d ₂ mm	l ₁ mm	l ₂ mm			
FRMD-FP07004A	7,0	7	63	19	4	●	1 u
FRMD-FP07004A-L	7,0	7	75	25	4	●	1 u
FRMD-FP08004A	8,0	8	63	20	4	●	1 u
FRMD-FP08004A-L	8,0	8	75	25	4	●	1 u
FRMD-FP08004A-XL	8,0	8	105	35	4	●	1 u
FRMD-FP08504A	8,5	9	80	22	4	●	1 u
FRMD-FP09004A	9,0	9	80	22	4	●	1 u
FRMD-FP09004A-L	9,0	9	105	38	4	●	1 u
FRMD-FP10004A	10,0	10	72	22	4	●	1 u
FRMD-FP10004A-L	10,0	10	105	38	4	●	1 u
FRMD-FP10004A-XL	10,0	10	150	75	4	●	1 u
FRMD-FP11004A	11,0	11	80	26	4	●	1 u
FRMD-FP11004A-L	11,0	11	105	38	4	●	1 u
FRMD-FP12004A	12,0	12	83	26	4	●	1 u
FRMD-FP12004A-L	12,0	12	105	50	4	●	1 u
FRMD-FP12004A-XL	12,0	12	150	75	4	●	1 u
FRMD-FP13004A	13,0	13	80	26	4	●	1 u
FRMD-FP13004A-L	13,0	13	125	56	4	●	1 u
FRMD-FP14004A	14,0	14	83	32	4	●	1 u
FRMD-FP14004A-L	14,0	14	125	56	4	●	1 u
FRMD-FP14004A-XL	14,0	14	150	75	4	●	1 u
FRMD-FP16004A	16,0	16	92	32	4	●	1 u
FRMD-FP16004A-L	16,0	16	150	75	4	●	1 u
FRMD-FP16004A-XL	16,0	16	200	75	4	●	1 u
FRMD-FP18004A	18,0	18	92	38	4	●	1 u
FRMD-FP18004A-L	18,0	18	150	75	4	●	1 u
FRMD-FP18004A-XL	18,0	18	200	75	4	●	1 u
FRMD-FP20004A	20,0	20	104	38	4	●	1 u
FRMD-FP20004A-L	20,0	20	150	75	4	●	1 u
FRMD-FP20004A-XL	20,0	20	200	75	4	●	1 u
FRMD-FP21004A	21,0	22	104	38	4	●	1 u
FRMD-FP22004A	22,0	22	104	38	4	●	1 u
FRMD-FP22004A-L	22,0	22	150	75	4	●	1 u
FRMD-FP24004A	24,0	25	121	45	4	●	1 u
FRMD-FP25004A	25,0	25	121	45	4	●	1 u
FRMD-FP25004A-L	25,0	25	150	75	4	●	1 u

● Producto estándar en stock ● Producto estándar a pedido ○ Producto especial a pedido

FRESAS PLANAS ANTIVIBRATORIAS

FRONTALES CON 3 FILOS

CARACTERÍSTICAS	
FORMA DE LA PUNTA	PLANA
TIPO	CON HÉLICE Y PASO DESIGUAL
CANTIDAD DE FILOS	Z = 3
ÁNGULO DE HÉLICE	$\lambda = 33^\circ$ a 37°
PASO	DESIGUAL
SENTIDO DE CORTE	DERECHO
FRENTE	CORTE AL CENTRO CON CHAFLANES DE PROTECCIÓN
TIPO DE MANGO	CILÍNDRICO SEGÚN DIN 6535 HB
LARGO DEL MANGO	SEGÚN TABLA
TOLERANCIA DEL MANGO	h6
TOLERANCIA DE LOS FILOS	h10
CALIDAD DEL METAL DURO	MICROGRANO
RECUBRIMIENTO	R302

▶ 3 FILOS



TIPOS DE MANGO: XC: EXTRA CORTO L: LARGO SIN REFERECIA: LARGO ESTANDAR (CORTO)

▶ CÓDIGO	▶ DESCRIPCIÓN				▶ FILOS	▶ DISPONIBILIDAD	▶ ENVASE
	▶ d ₁ mm	▶ d ₂ mm	▶ l ₁ mm	▶ l ₂ mm			
FRMD-FP06003A-1	6,0	6	57	19	3	●	1 u
FRMD-FP07003A-1	7,0	7	63	19	3	●	1 u
FRMD-FP08003A-1	8,0	8	63	20	3	●	1 u
FRMD-FP09003A-1	9,0	9	80	22	3	●	1 u
FRMD-FP10003A-1	10,0	10	72	22	3	●	1 u
FRMD-FP11003A-1	11,0	11	80	26	3	●	1 u
FRMD-FP12003A-1	12,0	12	83	26	3	●	1 u
FRMD-FP13003A-1	13,0	13	80	26	3	●	1 u
FRMD-FP14003A-1	14,0	14	83	32	3	●	1 u
FRMD-FP16003A-1	16,0	16	92	32	3	●	1 u
FRMD-FP18003A-1	18,0	18	92	38	3	●	1 u
FRMD-FP20003A-1	20,0	20	104	38	3	●	1 u
FRMD-FP22003A-1	22,0	22	104	38	3	●	1 u
FRMD-FP25003A-1	25,0	25	121	45	3	●	1 u

● Producto estándar en stock ◐ Producto estándar a pedido ○ Producto especial a pedido

FRESAS PLANAS HÉLICE VARIABLE

PREMIUM, FRONTALES CON 4 FILOS

CARACTERÍSTICAS	
FORMA DE LA PUNTA	PLANA
TIPO	HÉLICE VARIABLE
NORMA	DIN 6527 A
CANTIDAD DE FILOS	Z = 4
ÁNGULO DE HÉLICE	$\lambda = 41^\circ$ a 44°
PASO	DESIGUAL
DESCARGA	REBAJE ENTRE FILO Y MANGO
SENTIDO DE CORTE	DERECHO
FRENTE	CORTE AL CENTRO
TIPO DE MANGO	CILÍNDRICO SEGÚN DIN 6535 A
LARGO DEL MANGO	SEGÚN TABLA
TOLERANCIA DEL MANGO	h6
CALIDAD DEL METAL DURO	MICROGRANO
RECUBRIMIENTO	R302
APLICACIONES	ACEROS INOXIDABLES CON NÍQUEL

> 4 FILOS

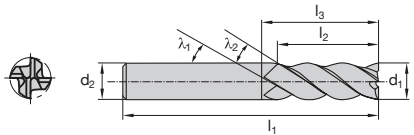



TIPOS DE MANGO: XC: EXTRA CORTO L: LARGO SIN REFERENCIA: LARGO ESTANDAR (CORTO)

CÓDIGO	DESCRIPCIÓN					R. EQUIV.	FILOS	DISPONIBILIDAD	ENVASE
	d ₁ mm	d ₂ mm	l ₁ mm	l ₂ mm	l ₃ mm				
FRMD-FP04004A-FHV	4,0	6	57	8	12	0,15	4	●	1 u
FRMD-FP05004A-FHV	5,0	6	57	10	15	0,20	4	●	1 u
FRMD-FP06004A-FHV	6,0	6	57	13	21	0,30	4	●	1 u
FRMD-FP08004A-FHV	8,0	8	63	19	27	0,30	4	●	1 u
FRMD-FP10004A-FHV	10,0	10	72	22	32	0,30	4	●	1 u
FRMD-FP12004A-FHV	12,0	12	83	26	38	0,30	4	●	1 u
FRMD-FP14004A-FHV	14,0	14	83	26	38	0,40	4	●	1 u
FRMD-FP16004A-FHV	16,0	16	92	32	44	0,40	4	●	1 u
FRMD-FP18004A-FHV	18,0	18	92	32	44	0,40	4	●	1 u
FRMD-FP20004A-FHV	20,0	20	104	38	54	0,40	4	●	1 u

● Producto estándar en stock ●● Producto estándar a pedido ○ Producto especial a pedido

FRESAS PLANAS COMBINADAS

(DESBASTE + TERMINACIÓN), FRONTALES CON 4 FILOS

CARACTERÍSTICAS	
FORMA DE LA PUNTA	PLANA
TIPO	COMBINADA -N
CANTIDAD DE FILOS	Z = 4
ÁNGULO DE HÉLICE	$\lambda = 38^\circ$
PASO	CONSTANTE
SENTIDO DE CORTE	DERECHO
FRENTE	CORTE AL CENTRO CON CHAFLANES DE PROTECCIÓN
TIPO DE MANGO	CILÍNDRICO SEGÚN DIN 6535 HB
LARGO DEL MANGO	SEGÚN TABLA
TOLERANCIA DEL MANGO	h6
TOLERANCIA DE LOS FILOS	h10
CALIDAD DEL METAL DURO	MICROGRANO
RECUBRIMIENTO	R302

▶ 4 FILOS

TIPOS DE MANGO: XC: EXTRA CORTO L: LARGO SIN REFERECIA: LARGO ESTANDAR (CORTO)

CÓDIGO	DESCRIPCIÓN				FILOS	DISPONIBILIDAD	ENVASE
	d ₁ mm	d ₂ mm	l ₁ mm	l ₂ mm			
FRMD-FP06004A-2	6,0	6	57	19	4	●	1 u
FRMD-FP07004A-2	7,0	7	63	19	4	●	1 u
FRMD-FP08004A-2	8,0	8	63	20	4	●	1 u
FRMD-FP09004A-2	9,0	9	80	22	4	●	1 u
FRMD-FP10004A-2	10,0	10	72	22	4	●	1 u
FRMD-FP11004A-2	11,0	11	80	26	4	●	1 u
FRMD-FP12004A-2	12,0	12	83	26	4	●	1 u
FRMD-FP13004A-2	13,0	13	80	26	4	●	1 u
FRMD-FP14004A-2	14,0	14	83	32	4	●	1 u
FRMD-FP16004A-2	16,0	16	92	32	4	●	1 u
FRMD-FP18004A-2	18,0	18	92	38	4	●	1 u
FRMD-FP20004A-2	20,0	20	104	38	4	●	1 u
FRMD-FP22004A-2	22,0	22	104	38	4	●	1 u
FRMD-FP25004A-2	25,0	25	121	45	4	●	1 u

● Producto estándar en stock ○ Producto estándar a pedido ○ Producto especial a pedido

FRESAS PLANAS PARA CONTORNEADO

NÚCLEO REFORZADO, FRONTALES CON 4 FILOS

CARACTERÍSTICAS	
FORMA DE LA PUNTA	PLANA
TIPO	N
CANTIDAD DE FILOS	Z = 4
ÁNGULO DE HÉLICE	$\lambda = 35^\circ$
PASO	CONSTANTE
SENTIDO DE CORTE	DERECHO
FRENTE	CORTE AL CENTRO
TIPO DE MANGO	CILÍNDRICO SEGÚN DIN 6535 A
LARGO DEL MANGO	SEGÚN TABLA
TOLERANCIA DEL MANGO	h6
TOLERANCIA DE LOS FILOS	h10
CALIDAD DEL METAL DURO	MICROGRANO
RECUBRIMIENTO	R302

▶ 4 FILOS

TIPOS DE MANGO: XC: EXTRA CORTO L: LARGO SIN REFERECIA: LARGO ESTANDAR (CORTO)

▶ CÓDIGO	▶ DESCRIPCIÓN				▶ FILOS	▶ DISPONIBILIDAD	▶ ENVASE
	▶ d ₁ mm	▶ d ₂ mm	▶ l ₁ mm	▶ l ₂ mm			
FRMD-FN02004A	2,0	6	57	7,5	4	●	1 u
FRMD-FN03004A	3,0	6	57	8,5	4	●	1 u
FRMD-FN04004A	4,0	6	57	11,5	4	●	1 u
FRMD-FN05004A	5,0	6	57	13,5	4	●	1 u
FRMD-FN06004A	6,0	6	57	13,5	4	●	1 u
FRMD-FN08004A	8,0	8	63	19,5	4	●	1 u
FRMD-FN10004A	10,0	10	72	22,5	4	●	1 u
FRMD-FN12004A	12,0	12	83	26,5	4	●	1 u
FRMD-FN14004A	14,0	14	83	26,5	4	●	1 u
FRMD-FN16004A	16,0	16	92	32,5	4	●	1 u
FRMD-FN18004A	18,0	18	92	32,5	4	●	1 u
FRMD-FN20004A	20,0	20	104	38,5	4	●	1 u

● Producto estándar en stock ● Producto estándar a pedido ○ Producto especial a pedido

FRESAS ESFÉRICAS

CON 2 FILOS

CARACTERÍSTICAS	
FORMA DE LA PUNTA	ESFÉRICA
TIPO	N
NORMA	DIN 6527 A
CANTIDAD DE FILOS	Z = 2
ÁNGULO DE HÉLICE	$\lambda = 30^\circ$
PASO	CONSTANTE
SENTIDO DE CORTE	DERECHO
FRENTE	CORTE AL CENTRO
TIPO DE MANGO	CILÍNDRICO SEGÚN DIN 6535 HA
LARGO DEL MANGO	SEGÚN TABLA
TOLERANCIA DEL MANGO	h6
TOLERANCIA DE LOS FILOS	h10
CALIDAD DEL METAL DURO	MICROGRANO
RECUBRIMIENTO	R302

▶ 2 FILOS

TIPOS DE MANGO: XC: EXTRA CORTO L: LARGO SIN REFERECIA: LARGO ESTANDAR (CORTO)

CÓDIGO	DESCRIPCIÓN				FILOS	DISPONIBILIDAD	ENVASE
	d ₁ mm	d ₂ mm	l ₁ mm	l ₂ mm			
FRMD-FE01002A	1,0	3	50	4	2	●	1 u
FRMD-FE01002A-XC	1,0	3	38	4	2	●	1 u
FRMD-FE01502A	1,5	3	50	4,5	2	●	1 u
FRMD-FE01502A-XC	1,5	3	38	4,5	2	●	1 u
FRMD-FE02002A	2,0	3	50	6,0	2	●	1 u
FRMD-FE02002A-XC	2,0	3	38	6,0	2	●	1 u
FRMD-FE02502A	2,5	3	50	9,5	2	●	1 u
FRMD-FE02502A-XC	2,5	3	38	9,5	2	●	1 u
FRMD-FE03002A	3,0	3	50	12	2	●	1 u
FRMD-FE03002A-L	3,0	3	75	25	2	●	1 u
FRMD-FE03002A-XC	3,0	3	38	12	2	●	1 u
FRMD-FE03502A	3,5	4	50	12	2	●	1 u
FRMD-FE03502A-L	3,5	4	75	25	2	●	1 u
FRMD-FE04002A	4,0	4	50	14	2	●	1 u
FRMD-FE04002A-L	4,0	4	75	25	2	●	1 u
FRMD-FE04502A	4,5	5	50	16	2	●	1 u
FRMD-FE04502A-L	4,5	5	75	25	2	●	1 u
FRMD-FE05002A	5,0	5	50	16	2	●	1 u
FRMD-FE05002A-L	5,0	5	75	25	2	●	1 u
FRMD-FE06002A	6,0	6	57	19	2	●	1 u
FRMD-FE06002A-L	6,0	6	75	25	2	●	1 u

● Producto estándar en stock ● Producto estándar a pedido ○ Producto especial a pedido

FRESAS ESFÉRICAS

CON 2 FILOS

CÓDIGO	DESCRIPCIÓN				FILOS	DISPONIBILIDAD	ENVASE
	d ₁ mm	d ₂ mm	l ₁ mm	l ₂ mm			
FRMD-FE07002A	7,0	7	63	19	2	●	1 u
FRMD-FE07002A-L	7,0	7	75	25	2	●	1 u
FRMD-FE08002A	8,0	8	63	20	2	●	1 u
FRMD-FE08002A-L	8,0	8	75	25	2	●	1 u
FRMD-FE09002A	9,0	9	80	22	2	●	1 u
FRMD-FE09002A-L	9,0	9	105	38	2	●	1 u
FRMD-FE10002A	10,0	10	72	22	2	●	1 u
FRMD-FE10002A-L	10,0	10	105	38	2	●	1 u
FRMD-FE11002A	11,0	11	80	26	2	●	1 u
FRMD-FE11002A-L	11,0	11	105	38	2	●	1 u
FRMD-FE12002A	12,0	12	83	26	2	●	1 u
FRMD-FE12002A-L	12,0	12	105	38	2	●	1 u
FRMD-FE13002A	13,0	13	80	26	2	●	1 u
FRMD-FE13002A-L	13,0	13	105	38	2	●	1 u
FRMD-FE14002A	14,0	14	83	32	2	●	1 u
FRMD-FE14002A-L	14,0	14	125	56	2	●	1 u
FRMD-FE15002A	15,0	16	92	32	2	●	1 u
FRMD-FE16002A	16,0	16	92	32	2	●	1 u
FRMD-FE16002A-L	16,0	16	150	75	2	●	1 u
FRMD-FE18002A	18,0	18	92	38	2	●	1 u
FRMD-FE18002A-L	18,0	18	150	75	2	●	1 u
FRMD-FE20002A	20,0	20	104	38	2	●	1 u
FRMD-FE20002A-L	20,0	20	150	75	2	●	1 u
FRMD-FE22002A	22,0	22	104	38	2	●	1 u
FRMD-FE22002A-L	22,0	22	150	75	2	●	1 u
FRMD-FE25002A	25,0	25	121	45	2	●	1 u
FRMD-FE25002A-L	25,0	25	150	75	2	●	1 u

● Producto estándar en stock ● Producto estándar a pedido ○ Producto especial a pedido

FRESAS ESFÉRICAS

CON 3 FILOS

CARACTERÍSTICAS	
FORMA DE LA PUNTA	ESFÉRICA
TIPO	N
NORMA	DIN 6527 A
CANTIDAD DE FILOS	Z = 3
ÁNGULO DE HÉLICE	$\lambda = 30^\circ$
PASO	CONSTANTE
SENTIDO DE CORTE	DERECHO
FRENTE	CORTE AL CENTRO
TIPO DE MANGO	CILÍNDRICO SEGÚN DIN 6535 HA
LARGO DEL MANGO	SEGÚN TABLA
TOLERANCIA DEL MANGO	h6
TOLERANCIA DE LOS FILOS	h10
CALIDAD DEL METAL DURO	MICROGRANO
RECUBRIMIENTO	R302

▶ 3 FILOS

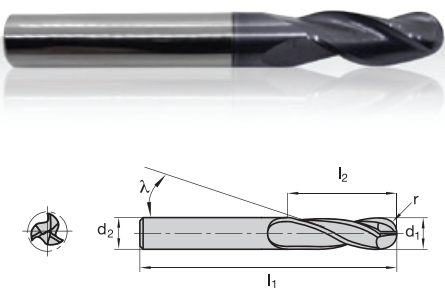

TIPOS DE MANGO: XC: EXTRA CORTO L: LARGO SIN REFERECIA: LARGO ESTANDAR (CORTO)

CÓDIGO	DESCRIPCIÓN				FILOS	DISPONIBILIDAD	ENVASE
	d ₁ mm	d ₂ mm	l ₁ mm	l ₂ mm			
FRMD-FE03003A	3,0	3	50	5	3	●	1 u
FRMD-FE03003A-L	3,0	3	75	25	3	●	1 u
FRMD-FE03003A-XC	3,0	3	38	12	3	○	1 u
FRMD-FE03003A-XL	3,0	3	105	6	3	●	1 u
FRMD-FE03503A	3,5	4	50	12	3	○	1 u
FRMD-FE03503A-L	3,5	4	75	25	3	○	1 u
FRMD-FE04003A	4,0	4	50	12	3	●	1 u
FRMD-FE04003A-L	4,0	4	75	25	3	●	1 u
FRMD-FE000016	4,0	4	105	6	3	●	1 u
FRMD-FE04003A-XL	4,0	4	105	25	3	●	1 u
FRMD-FE04503A	4,5	5	50	16	3	○	1 u
FRMD-FE04503A-L	4,5	5	75	25	3	○	1 u
FRMD-FE05003A	5,0	5	50	16	3	●	1 u
FRMD-FE05003A-L	5,0	5	75	25	3	●	1 u
FRMD-FE06003A	6,0	6	57	19	3	●	1 u
FRMD-FE06003A-L	6,0	6	75	25	3	●	1 u
FRMD-FE07003A	7,0	7	63	19	3	●	1 u
FRMD-FE07003A-L	7,0	7	75	25	3	●	1 u
FRMD-FE08003A	8,0	8	63	20	3	●	1 u
FRMD-FE08003A-L	8,0	8	75	25	3	●	1 u
FRMD-FE09003A	9,0	9	80	22	3	●	1 u

● Producto estándar en stock ○ Producto estándar a pedido ○ Producto especial a pedido

FRESAS ESFÉRICAS

CON 3 FILOS

CÓDIGO	DESCRIPCIÓN				FILOS	DISPONIBILIDAD	ENVASE
	d ₁ mm	d ₂ mm	l ₁ mm	l ₂ mm			
FRMD-FE09003A-L	9,0	9	105	38	3	●	1 u
FRMD-FE10003A	10,0	10	72	22	3	●	1 u
FRMD-FE10003A-L	10,0	10	105	38	3	●	1 u
FRMD-FE11003A	11,0	11	80	26	3	○	1 u
FRMD-FE11003A-L	11,0	11	105	38	3	○	1 u
FRMD-FE12003A	12,0	12	83	26	3	●	1 u
FRMD-FE12003A-L	12,0	12	105	50	3	●	1 u
FRMD-FE13003A	13,0	13	80	26	3	○	1 u
FRMD-FE13003A-L	13,0	13	105	50	3	○	1 u
FRMD-FE14003A	14,0	14	83	32	3	●	1 u
FRMD-FE14003A-L	14,0	14	125	56	3	●	1 u
FRMD-FE16003A	16,0	16	92	32	3	●	1 u
FRMD-FE16003A-L	16,0	16	150	75	3	●	1 u
FRMD-FE18003A	18,0	18	92	38	3	●	1 u
FRMD-FE18003A-L	18,0	18	150	75	3	●	1 u
FRMD-FE20003A	20,0	20	104	38	3	●	1 u
FRMD-FE20003A-L	20,0	20	150	75	3	●	1 u
FRMD-FE22003A	22,0	22	104	38	3	○	1 u
FRMD-FE22003A-L	22,0	22	150	75	3	○	1 u
FRMD-FE25003A	25,0	25	121	45	3	○	1 u
FRMD-FE25003A-L	25,0	25	150	75	3	○	1 u

● Producto estándar en stock ○ Producto estándar a pedido ○ Producto especial a pedido

FRESAS ESFÉRICAS

CON 4 FILOS

CARACTERÍSTICAS	
FORMA DE LA PUNTA	ESFÉRICA
TIPO	N
NORMA	DIN 6527 A
CANTIDAD DE FILOS	Z = 4
ÁNGULO DE HÉLICE	$\lambda = 30^\circ$
PASO	CONSTANTE
SENTIDO DE CORTE	DERECHO
FRENTE	CORTE AL CENTRO
TIPO DE MANGO	CILÍNDRICO SEGÚN DIN 6535 HA
LARGO DEL MANGO	SEGÚN TABLA
TOLERANCIA DEL MANGO	h6
TOLERANCIA DE LOS FILOS	h10
CALIDAD DEL METAL DURO	MICROGRANO
RECUBRIMIENTO	R302

▶ 4 FILOS

TIPOS DE MANGO: XC: EXTRA CORTO L: LARGO SIN REFERECIA: LARGO ESTANDAR (CORTO)

CÓDIGO	DESCRIPCIÓN				FILOS	DISPONIBILIDAD	ENVASE
	d ₁ mm	d ₂ mm	l ₁ mm	l ₂ mm			
FRMD-FE01004A	1	3	50	4	4	●	1 u
FRMD-FE01004A-XC	1	3	38	4	4	●	1 u
FRMD-FE01504A	1,5	3	50	4,5	4	●	1 u
FRMD-FE01504A-XC	1,5	3	38	4,5	4	●	1 u
FRMD-FE02004A	2,0	3	50	6,0	4	●	1 u
FRMD-FE02004A-XC	2,0	3	38	6,0	4	●	1 u
FRMD-FE02504A	2,5	3	50	9,5	4	●	1 u
FRMD-FE02504A-XC	2,5	3	38	9,5	4	●	1 u
FRMD-FE03004A	3,0	3	50	12	4	●	1 u
FRMD-FE03004A-L	3,0	3	75	25	4	●	1 u
FRMD-FE03504A	3,5	4	50	12	4	●	1 u
FRMD-FE03504A-L	3,5	4	75	25	4	●	1 u
FRMD-FE04004A	4,0	4	50	14	4	●	1 u
FRMD-FE04004A-L	4,0	4	75	25	4	●	1 u
FRMD-FE04504A	4,5	5	50	16	4	●	1 u
FRMD-FE04504A-L	4,5	5	75	25	4	●	1 u
FRMD-FE05004A	5,0	5	50	16	4	●	1 u
FRMD-FE05004A-L	5,0	5	75	25	4	●	1 u
FRMD-FE06004A	6,0	6	57	19	4	●	1 u
FRMD-FE06004A-L	6,0	6	75	25	4	●	1 u
FRMD-FE06004A-XL	6,0	6	105	12	4	●	1 u

● Producto estándar en stock ● Producto estándar a pedido ○ Producto especial a pedido

FRESAS ESFÉRICAS

CON 4 FILOS

CÓDIGO	DESCRIPCIÓN				FILOS	DISPONIBILIDAD	ENVASE
	d ₁ mm	d ₂ mm	l ₁ mm	l ₂ mm			
FRMD-FE06004A-XXL	6,0	6	150	75	4	●	1 u
FRMD-FE07004A	7,0	7	63	19	4	●	1 u
FRMD-FE07004A-L	7,0	7	75	25	4	●	1 u
FRMD-FE08004A	8,0	8	63	20	4	●	1 u
FRMD-FE08004A-L	8,0	8	75	25	4	●	1 u
FRMD-FE08004A-XL	8,0	8	105	15	4	●	1 u
FRMD-FE09004A	9,0	9	80	22	4	●	1 u
FRMD-FE09004A-L	9,0	9	105	38	4	●	1 u
FRMD-FE10004A	10,0	10	72	22	4	●	1 u
FRMD-FE10004A-L	10,0	10	105	38	4	●	1 u
FRMD-FE10004A-L-U1	10,0	10	105	20	4	●	1 u
FRMD-FE11004A	11,0	11	80	26	4	●	1 u
FRMD-FE11004A-L	11,0	11	105	38	4	●	1 u
FRMD-FE12004A	12,0	12	83	26	4	●	1 u
FRMD-FE12004A-L	12,0	12	105	50	4	●	1 u
FRMD-FE13004A	13,0	13	80	26	4	●	1 u
FRMD-FE13004A-L	13,0	13	105	50	4	●	1 u
FRMD-FE14004A	14,0	14	83	32	4	●	1 u
FRMD-FE14004A-L	14,0	14	125	56	4	●	1 u
FRMD-FE14004A-XL	14,0	14	150	75	4	●	1 u
FRMD-FE16004A	16,0	16	92	32	4	●	1 u
FRMD-FE16004A-L	16,0	16	150	75	4	●	1 u
FRMD-FE16004A-XL	16,0	16	200	75	4	●	1 u
FRMD-FE18004A	18,0	18	92	38	4	●	1 u
FRMD-FE18004A-L	18,0	18	150	75	4	●	1 u
FRMD-FE18004A-XL	18,0	18	200	75	4	●	1 u
FRMD-FE20004A	20,0	20	104	38	4	●	1 u
FRMD-FE20004A-L	20,0	20	150	75	4	●	1 u
FRMD-FE20004A-XL	20,0	20	200	75	4	●	1 u
FRMD-FE22004A	22,0	22	104	38	4	●	1 u
FRMD-FE22004A-L	22,0	22	150	75	4	●	1 u
FRMD-FE25004A	25,0	25	121	45	4	●	1 u
FRMD-FE25004A-L	25,0	25	150	75	4	●	1 u

● Producto estándar en stock ● Producto estándar a pedido ○ Producto especial a pedido

FRESAS ESFÉRICAS PARA COPIADO

CÓNICA, CON 2 FILOS

CARACTERÍSTICAS	
FORMA DE LA PUNTA	ESFÉRICA
TIPO	N
CANTIDAD DE FILOS	Z = 2
ÁNGULO DE HÉLICE	$\lambda = 30^\circ$
PASO	CONSTANTE
DESCARGA	CÓNICA
SENTIDO DE CORTE	DERECHO
TIPO DE MANGO	CILÍNDRICO SEGÚN DIN 6535 Ha
LARGO DEL MANGO	SEGÚN TABLA
TOLERANCIA DEL MANGO	h6
TOLERANCIA DE LOS FILOS	--
CALIDAD DEL METAL DURO	MICROGRANO
RECUBRIMIENTO	R302
APLICACIONES	HASTA 55 HRc

▶ 2 FILOS

TIPOS DE MANGO: XC: EXTRA CORTO L: LARGO SIN REFERENCIA: LARGO ESTANDAR (CORTO)

CÓDIGO	DESCRIPCIÓN							FILOS	DISPONIBILIDAD	ENVASE
	d ₁ mm	d ₂ mm	l ₁ mm	l ₂ mm	l ₃ mm	α	β			
FRMD-FE0303002A-CN	3,0	6	57	8	40	1,5°	3,0°	2	●	1 u
FRMD-FE0301502A-CN	3,0	6	80	6	63	1,5°	1,5°	2	●	1 u
FRMD-FE0403002A-CN	4,0	6	57	5	26	3,75°	3,0°	2	●	1 u
FRMD-FE040202A-CN	4,0	6	57	10	44	1,5°	2,0°	2	●	1 u
FRMD-FE040152A-CN-L	4,0	6	80	6	44	1,5°	1,5°	2	●	1 u
FRMD-FE060202A-CN	6,0	10	150	18	78	1,0°	2,0°	2	●	1 u
FRMD-FE080202A-CN	8,0	10	105	8	43	1,5°	2,0°	2	●	1 u
FRMD-FE080202A-CN-L	8,0	12	150	30	100	1,0°	2,0°	2	●	1 u

● Producto estándar en stock ● Producto estándar a pedido ○ Producto especial a pedido

FRESAS TÓRICAS

FRONTALES CON 4 FILOS

CARACTERÍSTICAS	
FORMA DE LA PUNTA	TÓRICA
TIPO	N
NORMA	DIN 6527 L
CANTIDAD DE FILOS	Z = 4
ÁNGULO DE HÉLICE	$\lambda = 30^\circ$
PASO	CONSTANTE
SENTIDO DE CORTE	DERECHO
FRENTE	CORTE AL CENTRO
TIPO DE MANGO	CILÍNDRICO SEGÚN DIN 6535 HA
LARGO DEL MANGO	SEGÚN TABLA
TOLERANCIA DEL MANGO	h6
TOLERANCIA DE LOS FILOS	h10
CALIDAD DEL METAL DURO	MICROGRANO
RECUBRIMIENTO	R302

> 4 FILOS

TIPOS DE MANGO: XC: EXTRA CORTO L: LARGO SIN REFERENCIA: LARGO ESTANDAR (CORTO)

CÓDIGO	DESCRIPCIÓN					DISPONIBILIDAD	ENVASE	
	d ₁ mm	d ₂ mm	l ₁ mm	l ₂ mm	CANTIDAD DE FILOS Z			r mm
FRMD-FT03054A	3,0	3	50	12	4	0,5	●	1 u
FRMD-FT03084A	3,0	3	50	12	4	0,8	●	1 u
FRMD-FT03084A-L	3,0	3	75	12	4	0,8	●	1 u
FRMD-FT03084A-XC	3,0	3	38	12	4	0,8	●	1 u
FRMD-FT04054A	4,0	4	50	12	4	0,5	●	1 u
FRMD-FT04084A	4,0	4	50	12	4	0,8	●	1 u
FRMD-FT04084A-L	4,0	4	75	12	4	1,0	●	1 u
FRMD-FT04104A	4,0	4	50	12	4	0,5	●	1 u
FRMD-FT06054A	6,0	6	57	13	4	0,5	●	1 u
FRMD-FT06054A-XL	6,0	6	105	15	4	0,5	●	1 u
FRMD-FT06054A-XL-R	6,0	6	105	34	4	1,0	●	1 u
FRMD-FT06104A	6,0	6	57	13	4	1,0	●	1 u
FRMD-FT06104A-L	6,0	6	90	13	4	1,0	●	1 u
FRMD-FT06104A-XL	6,0	6	105	15	4	1,0	●	1 u
FRMD-FT06104A-XL-R	6,0	6	105	34	4	1,0	●	1 u
FRMD-FT06104A-XXL	6,0	6	150	75	4	1,5	●	1 u
FRMD-FT06154A-XL	6,0	6	105	15	4	0,5	●	1 u
FRMD-FT08054A	8,0	8	63	20	4	0,5	●	1 u
FRMD-FT08054A-XL	8,0	8	105	20	4	0,5	●	1 u
FRMD-FT08054A-XL-R	8,0	8	105	40	4	1,0	●	1 u
FRMD-FT08104A	8,0	8	63	20	4	1,0	●	1 u

● Producto estándar en stock ● Producto estándar a pedido ○ Producto especial a pedido

FRESAS TÓRICAS

CON 4 FILOS

CÓDIGO	DESCRIPCIÓN						DISPONIBILIDAD	ENVASE
	d ₁ mm	d ₂ mm	l ₁ mm	l ₂ mm	CANTIDAD DE FILOS Z	r mm		
FRMD-FT08104A-XL	8,0	8	105	20	4	1,0	●	1 u
FRMD-FT08104A-XL-R	8,0	8	105	40	4	1,0	●	1 u
FRMD-FT08104A-XXL	8,0	8	150	75	4	1,0	●	1 u
FRMD-FT08154A	8,0	8	63	20	4	1,5	●	1 u
FRMD-FT08154A-XL	8,0	8	105	20	4	1,5	●	1 u
FRMD-FT08154A-XXL	8,0	8	150	75	4	1,5	●	1 u
FRMD-FT08204A	8,0	8	63	20	4	2,0	●	1 u
FRMD-FT08204A-XL	8,0	8	105	20	4	2,0	●	1 u
FRMD-FT10054A	10,0	10	72	22	4	0,5	●	1 u
FRMD-FT10054A-XL	10,0	10	105	22	4	0,5	●	1 u
FRMD-FT10054A-XL-R	10,0	10	105	45	4	0,5	●	1 u
FRMD-FT10084A	10,0	10	72	22	4	0,8	●	1 u
FRMD-FT10084A-XL	10,0	10	105	22	4	0,8	●	1 u
FRMD-FT10104A	10,0	10	72	22	4	1,0	●	1 u
FRMD-FT10104A-XL	10,0	10	105	22	4	1,0	●	1 u
FRMD-FT10154A	10,0	10	72	22	4	1,5	●	1 u
FRMD-FT10154A-XL	10,0	10	105	22	4	1,5	●	1 u
FRMD-FT10154A-XL-R	10,0	10	105	45	4	1,5	●	1 u
FRMD-FT10154A-XXL	10,0	10	150	75	4	1,5	●	1 u
FRMD-FT10204A	10,0	10	72	22	4	2,0	●	1 u
FRMD-FT10204A-XL	10,0	10	105	22	4	2,0	●	1 u
FRMD-FT12054A	12,0	12	83	26	4	0,5	●	1 u
FRMD-FT12054A-XL	12,0	12	105	26	4	0,5	●	1 u
FRMD-FT12054A-XL-R	12,0	12	105	47	4	0,5	●	1 u
FRMD-FT12084A	12,0	12	83	26	4	0,8	●	1 u
FRMD-FT12084A-XL	12,0	12	105	26	4	0,8	●	1 u
FRMD-FT12104A	12,0	12	83	26	4	1,0	●	1 u
FRMD-FT12104A-XL	12,0	12	105	26	4	1,0	●	1 u
FRMD-FT12153A	12,0	12	83	26	4	1,5	●	1 u
FRMD-FT12154A	12,0	12	83	26	4	1,5	●	1 u
FRMD-FT12154A-XL	12,0	12	105	26	4	1,5	●	1 u
FRMD-FT12154A-XXL	12,0	12	150	26	4	1,5	●	1 u
FRMD-FT12154A-XXL-U1	12,0	12	150	80	4	1,5	●	1 u
FRMD-FT12204A	12,0	12	83	26	4	2,0	●	1 u
FRMD-FT12204A-XL	12,0	12	105	26	4	2,0	●	1 u
FRMD-FT12204A-XL-R	12,0	12	105	47	4	2,0	●	1 u

● Producto estándar en stock ● Producto estándar a pedido ○ Producto especial a pedido

FRESAS DE RADIO CÓNCAVO

CON 4 FILOS

CARACTERÍSTICAS	
FORMA DE LA PUNTA	CÓNCAVA
TIPO	N
NORMA	DIN 6527 L
CANTIDAD DE FILOS	Z = 4
ÁNGULO DE HÉLICE	$\lambda = 30^\circ$
PASO	CONSTANTE
SENTIDO DE CORTE	DERECHO
TIPO DE MANGO	CILÍNDRICO SEGÚN DIN 6535 HA
LARGO DEL MANGO	SEGÚN TABLA
TOLERANCIA DEL MANGO	h6
TOLERANCIA DE LOS FILOS	--
CALIDAD DEL METAL DURO	MICROGRANO
RECUBRIMIENTO	R302
APLICACIONES	HASTA 60HRc

▶ 4 FILOS

TIPOS DE MANGO: XC: EXTRA CORTO L: LARGO SIN REFERECIA: LARGO ESTANDAR (CORTO)

▶ CÓDIGO	▶ DESCRIPCIÓN				▶ FILOS	▶ DISPONIBILIDAD	▶ ENVASE
	▶ d ₁ mm	▶ d ₂ mm	▶ l ₁ mm	▶ r mm			
FRMD-FC08054A	6,2	8	63	0,5	4	●	1 u
FRMD-FC08104A	5,3	8	63	1,0	4	●	1 u
FRMD-FC10154A	6,3	10	72	1,5	4	●	1 u
FRMD-FC10204A	5,4	10	72	2,0	4	●	1 u
FRMD-FC12254A	6,4	12	83	2,5	4	●	1 u
FRMD-FC12304A	5,5	12	83	3,0	4	●	1 u
FRMD-FC16354A	8,5	16	80	3,5	4	●	1 u
FRMD-FC16404A	7,5	16	80	4,0	4	●	1 u
FRMD-FC16454A	6,6	16	80	4,5	4	●	1 u

● Producto estándar en stock ● Producto estándar a pedido ○ Producto especial a pedido

FRESAS PARA ACHAFLANADO

CON 4 Y 6 FILOS

CARACTERÍSTICAS	
FORMA DE LA PUNTA	45°
TIPO	N
NORMA	DIN 6535 A
CANTIDAD DE FILOS	Z = 4 Y 6
ÁNGULO DE HÉLICE	$\lambda = 0^\circ$
PASO	CONSTANTE
SENTIDO DE CORTE	DERECHO
FRENTE	VÉRTICE EN PUNTA
TIPO DE MANGO	CILÍNDRICO SEGÚN DIN 6535 A
LARGO DEL MANGO	SEGÚN TABLA
TOLERANCIA DEL MANGO	h6
TOLERANCIA DE LOS FILOS	h10
CALIDAD DEL METAL DURO	MICROGRANO
RECUBRIMIENTO	R302
APLICACIONES	HASTA 55 HRC

▶ 4 Y 6 FILOS

TIPOS DE MANGO: XC: EXTRA CORTO L: LARGO SIN REFERENCIA: LARGO ESTANDAR (CORTO)

▶ CÓDIGO	▶ DESCRIPCIÓN					▶ FILOS	▶ DISPONIBILIDAD	▶ ENVASE
	▶ d ₁ mm	▶ d ₂ mm	▶ d ₃ mm	▶ l ₁ mm	▶ l ₂ mm			
FA06004A	6,0	6	2	58	2,5	4	●	1 u
FA12006A	12,0	12	3	82	4,5	6	●	1 u

● Producto estándar en stock ● Producto estándar a pedido ○ Producto especial a pedido

FRESAS PARA ROUTER UPCUT

FRONTALES CON 1 Y 2 FILOS

CARACTERÍSTICAS	
FORMA DE LA PUNTA	PLANA
TIPO	W
NORMA	DIN 6535 A
CANTIDAD DE FILOS	Z = 1 Y 2
ÁNGULO DE HÉLICE	$\lambda = 30^\circ$
PASO	CONSTANTE
SENTIDO DE CORTE	DERECHO
FRENTE	CORTE AL CENTRO
LARGO DEL MANGO	SEGÚN TABLA
TOLERANCIA DEL MANGO	h6
CALIDAD DEL METAL DURO	MICROGRANO
RECUBRIMIENTO	--
APLICACIONES	ALUMINIO, PLÁSTICOS POLIMÉRICOS, MADERAS BLANDAS, DURAS, AGLOMERADAS, PLÁSTICOS BLANDOS, DUROS

▶ 1 Y 2 FILOS

TIPOS DE MANGO: XC: EXTRA CORTO L: LARGO SIN REFERENCIA: LARGO ESTANDAR (CORTO)

CÓDIGO	DESCRIPCIÓN				FILOS	DISPONIBILIDAD	ENVASE
	d ₁ mm	d ₂ mm	l ₁ mm	l ₂ mm			
FRMD-FP02081-UC	2,0	3	50	8	1	●	1 u
FRMD-FP03121-UC	3,0	3	50	12	1	●	1 u
FRMD-FP03201-UC	3,0	3	50	20	1	●	1 u
FRMD-FP03132-UC	3,0	6	64	13	2	●	1 u
FRMD-FP04141-UC	4,0	4	50	14	1	●	1 u
FRMD-FP04201-UC	4,0	4	50	20	1	●	1 u
FRMD-FP04162-UC	4,0	6	64	16	2	●	1 u
FRMD-FP05161-UC	5,0	5	50	20	1	●	1 u
FRMD-FP05202-UC	5,0	6	64	20	2	●	1 u
FRMD-FP06251-UC	6,0	6	58	25	1	●	1 u
FRMD-FP06252-UC	6,0	6	64	25	2	●	1 u
FRMD-FP08252-UC	8,0	8	64	25	2	●	1 u

● Producto estándar en stock ● Producto estándar a pedido ○ Producto especial a pedido

FRESAS PARA ROUTER DOWNCUT

FRONTALES CON 1 Y 2 FILOS

CARACTERÍSTICAS		<p>▶ 1 Y 2 FILOS</p> 
FORMA DE LA PUNTA	PLANA	
TIPO	W	
NORMA	DIN 6535 A	
CANTIDAD DE FILOS	Z = 1 Y 2	
ÁNGULO DE HÉLICE	$\lambda = 30^\circ$	
PASO	CONSTANTE	
SENTIDO DE CORTE	DERECHO	
FRENTE	CORTE AL CENTRO	
LARGO DEL MANGO	SEGÚN TABLA	
TOLERANCIA DEL MANGO	h6	
CALIDAD DEL METAL DURO	MICROGRANO	
RECUBRIMIENTO	--	
APLICACIONES	ALUMINIO, PLÁSTICOS POLIMÉRICOS, MADERAS BLANDAS, DURAS, AGLOMERADAS, PLÁSTICOS BLANDOS, DUROS	

TIPOS DE MANGO: XC: EXTRA CORTO L: LARGO SIN REFERECIA: LARGO ESTANDAR (CORTO)

▶ CÓDIGO	▶ DESCRIPCIÓN				▶ FILOS	▶ DISPONIBILIDAD	▶ ENVASE
	▶ d ₁ mm	▶ d ₂ mm	▶ l ₁ mm	▶ l ₂ mm			
FRMD-FP02081-DC	2,0	3	50	8	1	●	1 u
FRMD-FP03121-DC	3,0	3	50	12	1	●	1 u
FRMD-FP03201-DC	3,0	3	50	20	1	●	1 u
FRMD-FP03132-DC	3,0	6	64	13	2	●	1 u
FRMD-FP04141-DC	4,0	4	50	14	1	●	1 u
FRMD-FP04201-DC	4,0	4	50	20	1	●	1 u
FRMD-FP04162-DC	4,0	6	64	16	2	●	1 u
FRMD-FP05161-DC	5,0	5	50	20	1	●	1 u
FRMD-FP05202-DC	5,0	6	64	20	2	●	1 u
FRMD-FP06251-DC	6,0	6	58	25	1	●	1 u
FRMD-FP06252-DC	6,0	6	64	25	2	●	1 u
FRMD-FP08252-DC	8,0	8	64	25	2	●	1 u

● Producto estándar en stock ● Producto estándar a pedido ○ Producto especial a pedido

FRESAS PARA ROUTER HÉLICES OPUESTAS

FRONTALES DE COMPRESIÓN

CARACTERÍSTICAS	
FORMA DE LA PUNTA	PLANA
TIPO	HÉLICE IZQUIERDA Y DERECHA
NORMA	DIN 6535 A
CANTIDAD DE FILOS	Z = 2
PASO	CONSTANTE
SENTIDO DE CORTE	DERECHO
FRENTE	CORTE AL CENTRO
LARGO DEL MANGO	SEGÚN TABLA
TOLERANCIA DEL MANGO	h6
CALIDAD DEL METAL DURO	MICROGRANO
RECUBRIMIENTO	--
APLICACIONES	MADERAS, AGLOMERADAS, TERCIAJAS

> 2 FILOS



TIPOS DE MANGO: XC: EXTRA CORTO L: LARGO SIN REFERENCIA: LARGO ESTANDAR (CORTO)

CÓDIGO	DESCRIPCIÓN				FILOS	DISPONIBILIDAD	ENVASE
	d ₁ mm	d ₂ mm	l ₁ mm	l ₂ mm			
FRMD-FP04202-HO	4,0	4	50	20	2	●	1 u
FRMD-FP06252-HO	6,0	6	64	25	2	●	1 u
FRMD-FP08252-HO	8,0	8	64	25	2	●	1 u
FRMD-FP10252-HO	10,0	10	73	25	2	●	1 u
FRMD-FP12352-HO	12,0	12	83	35	2	●	1 u
FRMD-FP127281-HO	12,7	12,7	75	28	2	●	1 u

● Producto estándar en stock ○ Producto estándar a pedido ○ Producto especial a pedido

FRESAS DE CANALES RECTOS

CON 2 FILOS

CARACTERÍSTICAS	
FORMA DE LA PUNTA	PLANA
TIPO	RECTA
NORMA	DIN 6535 A
CANTIDAD DE FILOS	Z = 2
PASO	CONSTANTE
SENTIDO DE CORTE	DERECHO
LARGO DEL MANGO	SEGÚN TABLA
TOLERANCIA DEL MANGO	h6
CALIDAD DEL METAL DURO	MICROGRANO
RECUBRIMIENTO	--
APLICACIONES	MADERAS, AGLOMERADAS

▶ 2 FILOS

TIPOS DE MANGO: XC: EXTRA CORTO L: LARGO SIN REFERECIA: LARGO ESTANDAR (CORTO)

▶ CÓDIGO	▶ DESCRIPCIÓN				▶ FILOS	▶ DISPONIBILIDAD	▶ ENVASE
	▶ d ₁ mm	▶ d ₂ mm	▶ l ₁ mm	▶ l ₂ mm			
FRMD-FR04002	4,0	4	64	16	2	●	1 u
FRMD-FR05002	5,0	5	64	20	2	●	1 u
FRMD-FR06002	6,0	6	64	25	2	●	1 u
FRMD-FR08002	8,0	8	76	25	2	●	1 u
FRMD-FR10002	10,0	10	83	35	2	●	1 u
FRMD-FR12002	12,0	12	83	35	2	●	1 u

● Producto estándar en stock ● Producto estándar a pedido ○ Producto especial a pedido

FRESAS PARA COPIADO, SUPERFINISH

CON 2 FILOS

CARACTERÍSTICAS	
FORMA DE LA PUNTA	ESFÉRICA, FILO TIPO "S" HASTA EL CENTRO
TIPO	HELICOIDAL
NORMA	DIN 6535 A
CANTIDAD DE FILOS	Z = 2
PASO	CONSTANTE
SENTIDO DE CORTE	DERECHO
LARGO DEL MANGO	SEGÚN TABLA
TOLERANCIA DEL MANGO	h6
CALIDAD DEL METAL DURO	MICROGRANO
RECUBRIMIENTO	R302
APLICACIONES Y TERMINACIÓN	ACEROS EN GENERAL Y ACEROS HASTA 65 HRC

▶ 2 FILOS





TIPOS DE MANGO: XC: EXTRA CORTO L: LARGO SIN REFERENCIA: LARGO ESTANDAR (CORTO)

CÓDIGO	DESCRIPCIÓN					FILOS	DISPONIBILIDAD	ENVASE
	d ₁ mm	d ₂ mm	l ₁ mm	l ₂ mm	l ₃ mm			
FRMD-FS04002A	4	4	57	19	5,0	2	●	1 u
FRMD-FS06002A	6	6	57	21	7,5	2	●	1 u
FRMD-FS08002A	8	8	63	27	10,0	2	●	1 u
FRMD-FS10002A	10	10	72	32	12,5	2	●	1 u
FRMD-FS12002A	12	12	83	38	15,0	2	●	1 u

● Producto estándar en stock ● Producto estándar a pedido ○ Producto especial a pedido

FRESAS PARA GRABADO

CON 2 FILOS

CARACTERÍSTICAS	
FORMA DE LA PUNTA	ESFÉRICA
TIPO	N
NORMA	DIN 6535 A
CANTIDAD DE FILOS	Z = 2
PASO	CONSTANTE
SENTIDO DE CORTE	DERECHO
LARGO DEL MANGO	SEGÚN TABLA
TOLERANCIA DEL MANGO	h6
CALIDAD DEL METAL DURO	MICROGRANO
RECUBRIMIENTO	--
APLICACIONES	MATERIALES EN GENERAL HASTA 55 HRc

▶ 2 FILOS

TIPOS DE MANGO: XC: EXTRA CORTO L: LARGO SIN REFERECIA: LARGO ESTANDAR (CORTO)

CÓDIGO	DESCRIPCIÓN					FILOS	DISPONIBILIDAD	ENVASE
	d ₁ mm	d ₂ mm	l ₁ mm	l ₂ mm	l ₃ mm			
FRMD-FG00502A	0,5	3	38	0,8	2,0	2	●	1 u
FRMD-FG00602A	0,6	3	38	1,0	2,4	2	●	1 u
FRMD-FG00802A	0,8	3	38	1,3	2,8	2	●	1 u
FRMD-FG01002A	1,0	3	38	1,6	3,0	2	●	1 u
FRMD-FG01202A	1,2	3	38	1,9	3,6	2	●	1 u
FRMD-FG01602A	1,6	3	38	2,5	4,8	2	●	1 u
FRMD-FG02002A	2,0	3	38	3,2	6,0	2	●	1 u
FRMD-FG02402A	2,4	3	38	3,8	3,8	2	●	1 u
FRMD-FG03002A	3,0	3	38	4,8	4,8	2	●	1 u

● Producto estándar en stock ● Producto estándar a pedido ○ Producto especial a pedido

MICROFRESAS

FRONTALES CON 2, 3 Y 4 FILOS

CARACTERÍSTICAS	
FORMA DE LA PUNTA	PLANA
TIPO	N
NORMA	DIN 6535 A
CANTIDAD DE FILOS	Z = 2, 3 Y 4
ÁNGULO DE HÉLICE	$\lambda = 30^\circ$
PASO	CONSTANTE
SENTIDO DE CORTE	DERECHO
FRENTE	PLANO
CORTE AL FRENTE	AL CENTRO
LARGO DEL MANGO	SEGÚN TABLA
TOLERANCIA DEL MANGO	h6
CALIDAD DEL METAL DURO	MICROGRANO
RECUBRIMIENTO	R302
APLICACIONES	USO GENERAL ACEROS

▶ 2, 3 Y 4 FILOS

TIPOS DE MANGO: XC: EXTRA CORTO L: LARGO SIN REFERECIA: LARGO ESTANDAR (CORTO)

CÓDIGO	DESCRIPCIÓN					FILOS	DISPONIBILIDAD	ENVASE
	d ₁ mm	d ₂ mm	l ₁ mm	l ₂ mm	l ₃ mm			
FRMD-FP00502A-MF	0,5	3	38	0,62	1,25	2	●	1 u
FRMD-FP00602A-MF	0,6	3	38	0,75	1,50	2	●	1 u
FRMD-FP00702A-MF	0,7	3	38	0,87	1,75	2	●	1 u
FRMD-FP00802A-MF	0,8	3	38	1,00	2,00	2	●	1 u
FRMD-FP00902A-MF	0,9	3	38	1,15	2,30	2	●	1 u
FRMD-FP01002A-MF	1,0	3	38	1,25	2,50	2	●	1 u
FRMD-FP00503A-MF	0,5	3	38	0,62	1,25	3	●	1 u
FRMD-FP00603A-MF	0,6	3	38	0,75	1,50	3	●	1 u
FRMD-FP00703A-MF	0,7	3	38	0,87	1,75	3	●	1 u
FRMD-FP00803A-MF	0,8	3	38	1,00	2,00	3	●	1 u
FRMD-FP00903A-MF	0,9	3	38	1,15	2,30	3	●	1 u
FRMD-FP01003A-MF	1,0	3	38	1,25	2,50	3	●	1 u
FRMD-FP00504A-MF	0,5	3	38	0,62	1,25	4	●	1 u
FRMD-FP00604A-MF	0,6	3	38	0,75	1,50	4	●	1 u
FRMD-FP00704A-MF	0,7	3	38	0,87	1,75	4	●	1 u
FRMD-FP00804A-MF	0,8	3	38	1,00	2,00	4	●	1 u
FRMD-FP00904A-MF	0,9	3	38	1,15	2,30	4	●	1 u
FRMD-FP01004A-MF	1,0	3	38	1,25	2,50	4	●	1 u

● Producto estándar en stock ● Producto estándar a pedido ○ Producto especial a pedido

MICROFRESA DESCARGA "R"

CON 2 FILOS

CARACTERÍSTICAS	
FORMA DE LA PUNTA	PLANA / ESFÉRICA
TIPO	N
NORMA	DIN 6527A
CANTIDAD DE FILOS	Z = 2
ÁNGULO DE HÉLICE	$\lambda = 30^\circ$
PASO	CONSTANTE
SENTIDO DE CORTE	DERECHO
FRENTE	CORTE AL CENTRO
TIPO DE MANGO	CILÍNDRICO DIN 6535A
LARGO DEL MANGO	SEGÚN TABLA
TOLERANCIA DEL MANGO	h6
TOLERANCIA DE LOS FILOS	h10
CALIDAD DEL METAL DURO	UTRAMICROGRANO
RECUBRIMIENTO	R302 Nano

> 2 FILOS





TIPOS DE MANGO: XC: EXTRA CORTO L: LARGO SIN REFERECIA: LARGO ESTANDAR (CORTO)

CÓDIGO PLANA	DESCRIPCIÓN					FILOS	DISPONIBILIDAD	ENVASE
	d ₁ mm	d ₂ mm	l ₁ mm	l ₂ mm	l ₃ mm			
FP00202A-MFDR	0,2	3	38	0,20	0,60	2	●	1 u
FP00402A-MFDR	0,4	3	38	0,40	1,20	2	●	1 u
FP00502A-MFDR	0,5	3	38	0,40	1,50	2	●	1 u
FP00602A-MFDR	0,6	3	38	0,60	1,80	2	●	1 u
FP00802A-MFDR	0,8	3	38	0,80	2,40	2	●	1 u
FP01002A-MFDR	1,0	3	38	1,00	2,40	2	●	1 u

● Producto estándar en stock ● Producto estándar a pedido ○ Producto especial a pedido

CÓDIGO ESFÉRICA	DESCRIPCIÓN					FILOS	DISPONIBILIDAD	ENVASE
	d ₁ mm	d ₂ mm	l ₁ mm	l ₂ mm	l ₃ mm			
FE00202A-MFDR	0,2	3	38	0,20	0,60	2	●	1 u
FE00402A-MFDR	0,4	3	38	0,40	1,20	2	●	1 u
FE00502A-MFDR	0,5	3	38	0,40	1,50	2	●	1 u
FE00602A-MFDR	0,6	3	38	0,60	1,80	2	●	1 u
FE00802A-MFDR	0,8	3	38	0,80	2,40	2	●	1 u
FE01002A-MFDR	1,0	3	38	1,00	2,40	2	●	1 u

● Producto estándar en stock ● Producto estándar a pedido ○ Producto especial a pedido

FRESAS PERFIL CIRCULAR

CON 3 Y 4 FILOS

CARACTERÍSTICAS	
FORMA DE LA PUNTA	ESFÉRICA
TIPO	N
NORMA	DIN 6527 A
CANTIDAD DE FILOS	3 Y 4
ÁNGULO DE HÉLICE	30°
PASO	CONSTANTE
SENTIDO DE CORTE	DERECHO
FRENTE	CORTE AL CENTRO
TIPO DE MANGO	CILINDRICO SEGÚN DIN 6535 A
LARGO DEL MANGO	SEGÚN TABLA
TOLERANCIA DEL MANGO	h6
TOLERANCIA DE LOS FILOS	FORMA $\pm 0,01\text{mm}$
CALIDAD DEL METAL DURO	MICROGRANO
RECUBRIMIENTO	R302

▶ 3 Y 4 FILOS





CÓDIGO	DESCRIPCIÓN						FILOS	DISPONIBILIDAD	ENVASE
	d ₁ mm	r ₁	r ₂	l ₂ mm	l ₁ mm	Ød ₂ (h ₆)			
FRMD-FB06003A	6	1	95	22	57	6	3	●	1 u
FRMD-FB08003A	8	1	90	25	63	8	3	●	1 u
FRMD-FB10004A	10	2	85	26	72	10	4	●	1 u
FRMD-FB12004A	12	2	80	28	83	12	4	●	1 u

Los radios de las fresas tienen una tolerancia máxima de fabricación de $\pm 0,01\text{ mm}$, lo que permite mecanizados de alta precisión.

● Producto estándar en stock ● Producto estándar a pedido ○ Producto especial a pedido

BROCAS



BROCAS PARA CHAPISTA

CON 4 FILOS



CÓDIGO	DESCRIPCIÓN			FILOS	DISPONIBILIDAD	ENVASE
	d ₁ mm	d ₂ mm	l ₁ mm			
BRRX-BR08004-CH	8,0	8,0	44	4	●	1 u

● Producto estándar en stock ● Producto estándar a pedido ○ Producto especial a pedido

BROCAS PARA CENTRAR NC

CON 2 FILOS



CÓDIGO	DESCRIPCIÓN			FILOS	ÁNGULO	DISPONIBILIDAD	ENVASE
	d mm	l ₁ mm	l ₂ mm				
BRMD-BR03002	3,0	15	50	2	90°	●	1 u
BRMD-BR04002	4,0	15	55	2	90°	●	1 u
BRMD-BR05002	5,0	15	60	2	90°	●	1 u
BRMD-BR06002	6,0	15	66	2	90°	●	1 u
BRMD-BR08002	8,0	20	79	2	90°	●	1 u
BRMD-BR10002	10,0	20	89	2	90°	●	1 u

● Producto estándar en stock ● Producto estándar a pedido ○ Producto especial a pedido

FRESAS

DE ACERO RÁPIDO



FRESAS PLANAS DIN 327

FRONTALES HSS -CO, CON 2 FILOS, CORTE AL CENTRO

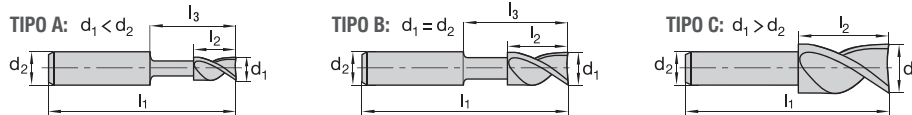

Tolerancia de mango: h7

Tolerancia de filo: e8

CÓDIGO	DESCRIPCIÓN					TIPO FIGURA	FILOS	DISPONIBILIDAD	ENVASE
	d ₁ mm	d ₂ mm	l ₁ mm	l ₂ mm	l ₃ mm				
FRMR-FP02002-HSSE	2,0	6	48	4,0	11	A	2	●	1 u
FRMR-FP02502-HSSE	2,5	6	49	5,0	12	A	2	●	1 u
FRMR-FP03002-HSSE	3,0	6	49	5	12	A	2	●	1 u
FRMR-FP03002-HSSE-L	3,0	6	56	12	19	A	2	●	1 u
FRMR-FP04002-HSSE	4,0	6	51	7	14	A	2	●	1 u
FRMR-FP04002-HSSE-L	4,0	6	63	19	26	A	2	●	1 u
FRMR-FP05002-HSSE	5,0	6	52	8	15	A	2	●	1 u
FRMR-FP05002-HSSE-L	5,0	6	68	24	32	A	2	●	1 u
FRMR-FP05502-HSSE	5,5	6	52	8	16	A	2	●	1 u
FRMR-FP06002-HSSE	6,0	6	52	8	16	B	2	●	1 u
FRMR-FP06002-HSSE-L	6,0	6	68	24	32	B	2	●	1 u
FRMR-FP06502-HSSE	6,5	10	60	10	19	A	2	●	1 u
FRMR-FP07002-HSSE	7,0	10	60	10	19	A	2	●	1 u
FRMR-FP08002-HSSE	8,0	10	61	11	20	A	2	●	1 u
FRMR-FP08002-HSSE-L	8,0	10	88	38	47	A	2	●	1 u
FRMR-FP09002-HSSE	9,0	10	61	11	21	A	2	●	1 u
FRMR-FP10002-HSSE	10,0	10	63	13	23	B	2	●	1 u
FRMR-FP10002-HSSE-L	10,0	10	95	45	55	B	2	●	1 u
FRMR-FP11002-HSSE	11,0	12	73	16	28	A	2	●	1 u
FRMR-FP12002-HSSE	12,0	12	73	16	28	B	2	●	1 u
FRMR-FP12002-HSSE-L	12,0	12	110	53	65	B	2	●	1 u
FRMR-FP13002-HSSE	13,0	12	73	16	--	C	2	●	1 u
FRMR-FP14002-HSSE	14,0	12	73	16	--	C	2	●	1 u
FRMR-FP14002-HSSE-L	14,0	12	110	53	--	C	2	●	1 u
FRMR-FP15002-HSSE	15,0	12	73	16	--	C	2	●	1 u
FRMR-FP16002-HSSE	16,0	16	79	19	31	B	2	●	1 u

● Producto estándar en stock ● Producto estándar a pedido ○ Producto especial a pedido

FRESAS PLANAS DIN 844

FRONTALES HSS -CO, CON 4 FILOS, CORTE AL CENTRO

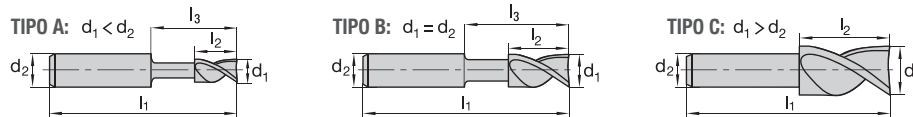

Tolerancia de mango: h7

Tolerancia de filo: $d_1 = d_2 \rightarrow h10$
Tolerancia de filo: $d_1 \neq d_2 \rightarrow k10$

CÓDIGO	DESCRIPCIÓN					TIPO FIGURA	FILOS	DISPONIBILIDAD	ENVASE
	$\triangleright d_1$ mm	$\triangleright d_2$ mm	$\triangleright l_1$ mm	$\triangleright l_2$ mm	$\triangleright l_3$ mm				
FRMR-FP03004-HSSE	3,0	6	52	8	14,0	A	4	●	1 u
FRMR-FP03004-HSSE-L	3,0	6	56	12	21,0	A	4	●	1 u
FRMR-FP03504-HSSE	3,5	6	55	11	18,0	A	4	●	1 u
FRMR-FP04004-HSSE	4,0	6	55	11	18,0	A	4	●	1 u
FRMR-FP04004-HSSE-L	4,0	6	63	19	27,0	A	4	●	1 u
FRMR-FP05004-HSSE	5,0	6	57	13	21,0	A	4	●	1 u
FRMR-FP05004-HSSE-L	5,0	6	68	24	33,0	A	4	●	1 u
FRMR-FP05504-HSSE	5,5	6	57	13	21,0	A	4	●	1 u
FRMR-FP06004-HSSE	6,0	6	57	13	21,0	B	4	●	1 u
FRMR-FP06004-HSSE-L	6,0	6	68	24	32,0	B	4	●	1 u
FRMR-FP06504-HSSE	6,5	10	66	16	24,0	A	4	●	1 u
FRMR-FP07004-HSSE	7,0	10	66	16	24,0	A	4	●	1 u
FRMR-FP08004-HSSE	8,0	10	69	19	27,0	A	4	●	1 u
FRMR-FP08004-HSSE-L	8,0	10	88	38	50,0	A	4	●	1 u
FRMR-FP08504-HSSE	8,5	10	69	19	27,0	A	4	●	1 u
FRMR-FP09004-HSSE	9,0	10	69	19	27,0	A	4	●	1 u
FRMR-FP09504-HSSE	9,5	10	69	19	27,0	A	4	●	1 u
FRMR-FP10004-HSSE	10,0	10	72	22	31,0	B	4	●	1 u
FRMR-FP10004-HSSE-L	10,0	10	95	45	54,0	B	4	●	1 u
FRMR-FP11004-HSSE	11,0	12	79	22	33,0	A	4	●	1 u
FRMR-FP12004-HSSE	12,0	12	83	26	38,0	B	4	●	1 u
FRMR-FP12004-HSSE-L	12,0	12	110	53	65,0	B	4	●	1 u
FRMR-FP13004-HSSE	13,0	12	83	26	--	C	4	●	1 u
FRMR-FP14004-HSSE	14,0	12	83	26	--	C	4	●	1 u
FRMR-FP14004-HSSE-L	14,0	12	110	53	--	C	4	●	1 u
FRMR-FP15004-HSSE	15,0	12	83	26	--	C	4	●	1 u
FRMR-FP16004-HSSE	16,0	16	92	32	44,0	B	4	●	1 u

● Producto estándar en stock ● Producto estándar a pedido ○ Producto especial a pedido

FRESOLINES HSS -Co

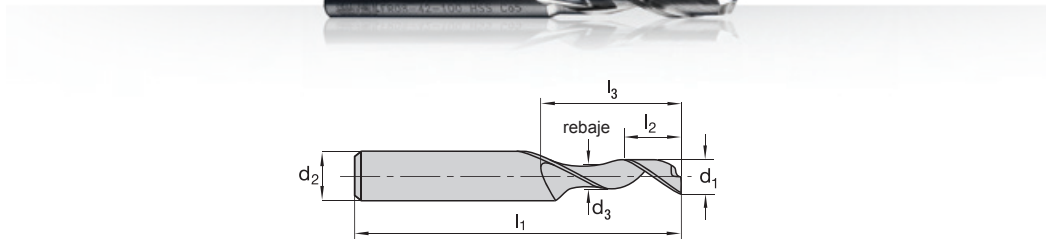

Tolerancia de mango: h7

Tolerancia de filo: $d_1 = d_2 \rightarrow h11$
Tolerancia de filo: $d_1 < d_2 \rightarrow k11$

CÓDIGO	DESCRIPCIÓN					FILOS	OBSERV.	DISPONIBILIDAD	ENVASE 1 u
	d ₁ mm	d ₂ mm	l ₁ mm	l ₂ mm	l ₃ mm				
FRMR-FR03-13-60	3,0	8	60	13	--	1	--	●	1 u
FRMR-FR04-13-70	4,0	8	70	13	--	1	--	●	1 u
FRMR-FR04-16-80R	4,0	8	80	16	45	1	CON REBAJE	●	1 u
FRMR-FR05-16-70	5,0	8	70	16	--	1	--	●	1 u
FRMR-FR05-16-80R	5,0	8	80	16	45	1	CON REBAJE	●	1 u
FRMR-FR05-42-100	5,0	8	100	42	--	1	--	●	1 u
FRMR-FR06-16-60-M	6,0	6	60	16	--	1	MINICOPY	●	1 u
FRMR-FR06-16-70	6,0	8	70	16	--	1	--	●	1 u
FRMR-FR06-16-70-1	6,0	8	70	16	--	1	NÚCLEO REFORZADO	●	1 u
FRMR-FR06-16-90	6,0	8	90	16	--	1	--	●	1 u
FRMR-FR06-16-90R	6,0	8	90	16	45	1	CON REBAJE	●	1 u
FRMR-FR06-42-100	6,0	8	100	42	--	1	--	●	1 u
FRMR-FR07-16-70	7,0	8	70	16	--	1	--	●	1 u
FRMR-FR08-16-80	8,0	8	80	16	--	1	--	●	1 u
FRMR-FR08-28-100R	8,0	8	100	28	67	1	CON REBAJE	●	1 u
FRMR-FR08-42-100	8,0	8	100	42	0	1	--	●	1 u

● Producto estándar en stock ● Producto estándar a pedido ○ Producto especial a pedido

PINZAS ER

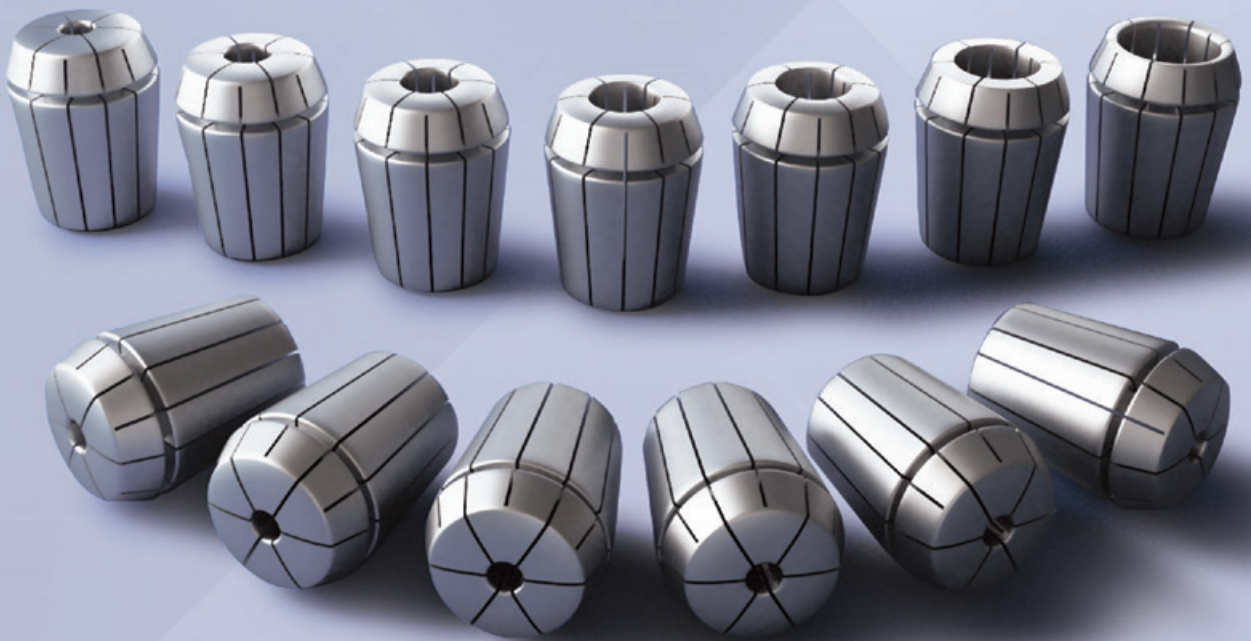

PINZAS ER



▶ VALIJA	▶ CÓDIGO	▶ CONTENIDO	▶ MODELO	▶ RANGO
	POBO-KITER16-10	KIT DE 10 UNIDADES	ER 16	∅ 0,5 mm - ∅ 10 mm
	POBO-KITER20-13	KIT DE 13 UNIDADES	ER 20	∅ 0,5 mm - ∅ 13 mm
	POBO-KITER25-15	KIT DE 15 UNIDADES	ER 25	∅ 1 mm - ∅ 16mm
	POBO-KITER32-19	KIT DE 19 UNIDADES	ER 32	∅ 1 mm - ∅ 20mm
	POBO-KITER40-24	KIT DE 24 UNIDADES	ER 40	∅ 2 mm - ∅ 26mm

HERRAMIENTAS ESPECIALES



CUCHILLAS PARA ROUTER

FILO ESPEJO



CÓDIGO	MODELO	DESCRIPCIÓN		DISPONIBILIDAD	ENVASE
		d mm	FILOS Z		
CUXP-42447235	TIPO 1	8,0	2 de 30°	●	1 u
CUXP-42447284	TIPO 3	8,0	2 de 40°	●	1 u
CUXP-42438135	TIPO 2	6,0	1	●	1 u

● Producto estándar en stock ● Producto estándar a pedido ○ Producto especial a pedido

FRESAS ESPECIALES A PEDIDO

DE METAL DURO INTEGRAL



DESARROLLAMOS FRESAS ESPECIALES A PEDIDO

- | | |
|--|---|
| ▶ FRESAS FRONTALES, ESFÉRICAS, TÓRICAS PARA RANURADO DE CHAVETAS, COPIADO, CAJEADORAS. | ▶ CON ÁNGULOS DE HÉLICE DE 20°, 25°, 30°, 33°, 41°, 45° y A MEDIDA. |
| ▶ CON 2, 3, 4 O MÚLTIPLES FILOS. | ▶ CON HÉLICE A IZQUIERDA Y A DERECHA. |
| ▶ CON CORTE HASTA EL CENTRO. | ▶ CON HÉLICE DE PASO VARIABLE. |
| ▶ CON BISEL PROTECTOR DE FILO. | ▶ CON MANGOS CILÍNDRICOS, SEGÚN NORMA DIN 6535 HA Y HB. |
| ▶ CON HÉLICE DE PASO CERRADA PARA EL ACABADO DE ACERO TEMPLADO. | ▶ CON MANGOS EXTRA-CORTOS, CORTOS, LARGOS Y EXTRA-LARGOS. |
| ▶ CON RADIO DE ESQUINA O PUNTA ESFÉRICA. | ▶ Y MUCHAS MÁS, DESAFÍENOS! |

SERVICIO DE REAFILADO

¡Le ofrecemos el único servicio de reafilado original del país! Reafilamos fresas de metal duro integral de todas las marcas (desde 6mm de diámetro en adelante).

Garantizamos el reafilado y el recubrimiento.

¡Consulte por cantidades mínimas!



RECOMENDACIONES DE PARÁMETROS DE CORTE

FAMILIA	MATERIAL	Rm/UTS (N/mm ²)	EJEMPLO			AVANCE POR DIENTE f _z (mm/z)				
			DESCRIPCIÓN	DIN	AISI	VELOCIDAD DE CORTE v _c (m/min)	Ø 2-4 mm	Ø 5-10 mm	Ø 11-16 mm	Ø >16 mm
P	ACERO DE CONSTRUCCIÓN NO ALEADO	-700	St 52	1.0052	1010	230	0,030	0,060	0,09	0,15
	ACERO DE FÁCIL MECANIZADO	-700	9 SMn 28	1.0715	1213	230	0,030	0,060	0,09	0,15
	ACERO DE CONSTRUCCIÓN	500-950	Ck 45 26 CrMo4	1.1191 1.7219	C1045 4132	200	0,025	0,060	0,08	0,14
	ACERO BONIFICADO, RESISTENCIA MEDIA	500-950	42 CrMo4 50CrV4	1.7225 1.2241	4140 6150	140	0,025	0,050	0,08	0,14
	ACERO FUNDIDO	-950	GS40	1.0416	1020	120	0,020	0,040	0,07	0,13
	ACERO DE CEMENTACIÓN	-950	16 MnCr 5	1.7131	5115/5117	140	0,030	0,050	0,08	0,14
	ACERO INOXIDABLE Y RESISTENTE A LOS ÁCIDOS, FERRÍTICO, MARTENSÍTICO	500-950	X 10 Cr 13 X 12 CrMoS 17 X 35 CrMo 17	1.4006 1.4104 1.4122	410 430F 440	80	0,015	0,035	0,07	0,10
	ACERO BONIFICADO, RESISTENCIA ALTA	950-1400	42 CrMo 4 30 CrNiMo 8	1.7225 1.6580	4140H 4340	110	0,015	0,040	0,06	0,12
	ACERO PARA NITRURAR, BONIFICADO	950-1400	34 CrAl 6	1.8504	--	100	0,015	0,040	0,06	0,12
	ACERO PARA HERRAMIENTAS	950-1400	X 38 CrMoV 5 1 X 155 CrVMo 12 1	1.2343 1.2379	H11 D2	100	0,015	0,040	0,06	0,12
M	ACERO INOXIDABLE Y RESISTENTE A LOS ÁCIDOS, AUSTENÍTICO	500-950	X 5 CrNi 18 10 X 10 CrNiMo 18 10	1.4307 1.4571	304L 316Ti	60	0,013	0,035	0,05	0,08
	ACERO MARTENSÍTICO TEMPLABLE		X 3 NiCoMoTi 18 9 5	1.2709	--	180	0,013	0,035	0,05	0,18
K	FUNDICIÓN GRIS	-550	GG25	0.6025	ASTM A48	180	0,030	0,070	0,10	0,15
	FUNDICIÓN GRIS ALEADA	300-700	GGL-NiCr 35 2	0.6678	ASTM A532	160	0,025	0,060	0,09	0,14
	FUNDICIÓN ESFEROIDAL	-500	GGG60	0.7060	ASTM A536	150	0,020	0,060	0,09	0,14
	FUNDICIÓN MALEABLE	40-70	GTS55	0.8155	ASTM A439	120	0,020	0,060	0,09	0,14

FAMILIA	MATERIAL	Rm/UTS (N/mm ²)	EJEMPLO			AVANCE POR DIENTE f _z (mm/z)				
			DESCRIPCIÓN	DIN	AISI	VELOCIDAD DE CORTE v _c (m/min)	Ø 2-4 mm	Ø 5-10 mm	Ø 11-16 mm	Ø >16 mm
N	METALES PUROS, BLANDOS	400-800 (120-310 HB)	Hierro puro, plomo	1.1003	PLOMO	400	0,020	0,040	0,08	0,14
	ALEACIONES DE ALUMINIO, DE VIRUTA LARGA	100-400 (120-310 HB)	AlMg 3	3.3535	EN AW 5754	1000	0,030	0,000	0,10	0,15
			AlZnMgCu 1,5	3.4365	EN AW 7075					
	ALEACIONES DE ALUMINIO, DE VIRUTA CORTA	-400	G-AISI 12	3.2581	G-AISI 12	300	0,030	0,060	0,10	0,15
	ALEACIONES DE COBRE, DE VIRUTA LARGA	150-250 (160-230 HB)	MS63	2.0320	Latón 63	300	0,025	0,050	0,09	0,14
			CuAl10Ni	2.0975	AFNOR U-A 10 N					
	ALEACIONES DE COBRE, DE VIRUTA CORTA	-500	MS58	2.0402	Latón 58	250	0,025	0,050	0,09	0,14
ALEACIONES DE MAGNESIO	160-300	G-MgAl9Zn1	3.5912	Magnesio Az 91 D	400	0,030	0,060	0,09	0,14	
TERMOPLÁSTICOS	300-700 (150-280 HB)	PVC, vidrio acrílico			250	0,030	0,060	0,10	0,15	
DUROPLÁSTICOS	20-40	Baquelita, melamina	1.1191	C1045	350	0,025	0,050	0,10	0,15	
S	GRAFITO		Grafito	R8510	Grafito	400	0,040	0,080	0,15	0,20
	ALEACIONES DE TITANIO, RESISTENCIA MEDIA	-950	TiAl5Sn2,5	3.7115	ASTM serie grado 6	70	0,015	0,030	0,05	0,09
			TiAl6V4	3.7165	ASTM B265					
	ALEACIONES DE TITANIO, RESISTENCIA ALTA	900-1400	TiAl6Sn2	3.7174	AMS 4971/ 4978	40	0,010	0,030	0,05	0,09
	ALEACIONES DE NÍQUEL, RESISTENCIA MEDIA	-950	NiCr12Al6MoNb	2.4670	Aleación 713 LC Inconel 713	30	0,010	0,030	0,05	0,09
ALEACIONES DE NÍQUEL, ALTA RESISTENCIA AL CALOR	900-1400	NiCr19Fe19NbMo Inconel 718		ASTM B637/ B670	20	0,010	0,030	0,05	0,09	
H	FUNDICIÓN DURA	300-600	Ni-hard, Ampco	Ampco 25	Ampco 25	50	0,010	0,030	0,05	0,09
	ACERO TEMPLADO	45-52 HRC 53-59 HRC				80-160	0,010	0,030	0,05	0,09

FÓRMULAS DE CÁLCULO

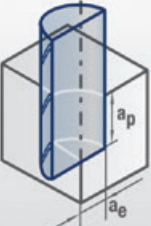
FACTORES DE CORRECCIÓN DE AVANCE F2 PARA FRESAS DE METAL DURO INTEGRAL				
$v_f = f_z \cdot z \cdot n \cdot f_2$				
	a_e	λ	$a_p \approx$	TIPO N
	$0,1 \cdot d_1$	$25^\circ - 30^\circ$	$1,5 \cdot d_1$	1
		45°	$1,5 \cdot d_1$	1,5
	$0,5 \cdot d_1$	$25^\circ - 30^\circ$	$1 \cdot d_1$	0,6
		45°	$1 \cdot d_1$	0,9
	$0,1 \cdot d_1$	$25^\circ - 30^\circ$	$0,5 \cdot d_1$	0,4
		45°	$0,8 \cdot d_1$ $0,5 \cdot d_1$	0,4 0,6

REVOLUCIONES

$$n = \frac{V_c \cdot 1000}{\pi \cdot d_1}$$

VELOCIDAD DE AVANCE

$$V_f = f_z \cdot z \cdot n \cdot f_2$$

REFERENCIAS

a_e	Anchura de corte en mm
a_p	Profundidad de corte en mm
d_1	Diámetro en mm
f_2	Factor de corrección para v_f
f_z	Avance por diente en mm
n	Revoluciones por minuto
v_c	Velocidad de corte en m/min
v_f	Velocidad de avance en mm/min
z	Número de filos
λ	Hélice ↗

► FORMULARIO DE SOLICITUD DE COTIZACIÓN

FRESAS ESPECIALES DE METAL DURO INTEGRAL

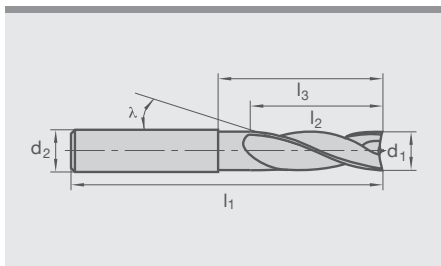

FECHA

RAZÓN SOCIAL

DIRECCIÓN

PERSONA DE CONTACTO

TELÉFONO

E-MAIL

DIÁMETRO CORTANTE (mm)	d1	Tolerancia	
DIÁMETRO DEL MANGO (mm)	d2	Tolerancia = h6	
LARGO TOTAL (mm)	l1		
LARGO DE CORTE (mm)	l2		
DESCARGA (mm)	Sí <input type="checkbox"/>	l3	No <input type="checkbox"/>
RADIO DE ESQUINA	Sí <input type="checkbox"/>	rE	No <input type="checkbox"/>
RADIO COMPLETO	Sí <input type="checkbox"/>	r	No <input type="checkbox"/>
CANTIDAD DE FILOS	Z=		
CORTA FRONTALMENTE	Sí <input type="checkbox"/>	No <input type="checkbox"/>	
CÓNICA	Sí <input type="checkbox"/>	No <input type="checkbox"/>	
REFRIGERACIÓN INTERIOR	Con <input type="checkbox"/>	Sin <input type="checkbox"/>	
ÁNGULO DE HÉLICE	λ =		
SENTIDO DE LA HÉLICE	Izquierda <input type="checkbox"/>	Derecha <input type="checkbox"/>	Recta <input type="checkbox"/>
SENTIDO DE CORTE	Izquierdo <input type="checkbox"/>	Derecho <input type="checkbox"/>	
MANGO SEGÚN DIN 6535	Forma HA <input type="checkbox"/>	Forma HB <input type="checkbox"/>	
RECUBRIMIENTO	sin <input type="checkbox"/>	TiAlN <input type="checkbox"/>	TiCN <input type="checkbox"/> TiN <input type="checkbox"/> Otro <input type="checkbox"/>

CANTIDAD DE FRESAS A COTIZAR

COMENTARIOS ADICIONALES

► **FORMULARIO DE SOLICITUD DE COTIZACIÓN**

REAFILADO DE FRESAS DE METAL DURO INTEGRAL

ESTIMADO CLIENTE:

EN SIN PAR NOS ESFORZAMOS NO SÓLO POR FABRICAR HERRAMIENTAS DE LA MÁS ALTA CALIDAD, SINO TAMBIÉN POR BRINDARLE EL MEJOR SERVICIO. PARA LOGRAR ESTE OBJETIVO, LE SOLICITAMOS QUE COMPLETE EL SIGUIENTE FORMULARIO CON LA MAYOR CANTIDAD DE INFORMACIÓN POSIBLE. DESDE YA, MUCHAS GRACIAS.

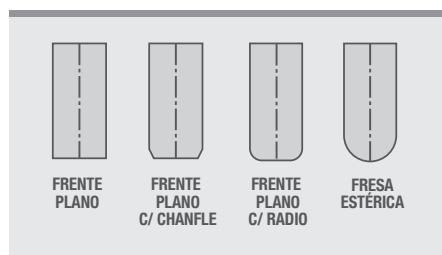

FECHA: _____

VENDEDOR ASIGNADO: _____

E-MAIL: _____

CUSTOMER INTERVINIENTE: _____

E-MAIL: _____

DATOS DEL CLIENTE:	Datos a completar por Of. Técnica Sin Par S.A.
DIRECCIÓN:	N° ítem NEat:
PERSONA DE CONTACTO:	Cantidad:
TELÉFONO:	
E-MAIL:	

INDICACIONES MÍNIMAS NECESARIAS	MARQUE CON UNA X LA OPCIÓN QUE CORRESPONDA			OBSERVACIONES ADICIONALES
	SÍ	NO	APLICAR CRITERIO AFILADOR	
REAFILAR FRENTE (PLANO, (PLANO+CHANFLE, ESFÉRICO O TÓRICO)	<input type="checkbox"/>	<input type="checkbox"/>	<input type="checkbox"/>	MEDIDA DEL CHANFLE (mm): MEDIDA DE RADIO PARA TÓRICAS (mm):
REAFILAR DIÁMETRO EXTERIOR	<input type="checkbox"/>	<input type="checkbox"/>	<input type="checkbox"/>	
RESPECTAR UN DIÁMETRO MÍNIMO	<input type="checkbox"/>	<input type="checkbox"/>		INDICAR DIÁMETRO MÍNIMO (mm):
REAFILAR CONO (EN CASO DE FRESAS CÓNICAS)	<input type="checkbox"/>	<input type="checkbox"/>	<input type="checkbox"/>	INDICAR ÁNGULO (°):
CONVERTIR FRESA A PLANA	<input type="checkbox"/>	<input type="checkbox"/>	<input type="checkbox"/>	
CONVERTIR FRESA A PLANA + CHANFLE	<input type="checkbox"/>	<input type="checkbox"/>		MEDIDA DE CHANFLE (mm x °):
CONVERTIR FRESA A TÓRICA	<input type="checkbox"/>	<input type="checkbox"/>		MEDIDA DEL RADIO (mm):
CONVERTIR FRESA A ESFÉRICA	<input type="checkbox"/>	<input type="checkbox"/>		LARGO MÍNIMO (mm)
REVESTIR LUEGO DEL REAFILADO	<input type="checkbox"/>	<input type="checkbox"/>	VER NOTA C	
RESPECTAR UN LARGO TOTAL MÍNIMO	<input type="checkbox"/>	<input type="checkbox"/>		LARGO TOTAL MÍNIMO (mm):
EMITIR INFORME DE DIÁMETROS	<input type="checkbox"/>	<input type="checkbox"/>	VER NOTA E	

NOTAS

- Le solicitamos completar todos los casilleros con una X, ya sea por "SI", "NO" o "Aplicar criterio del afilador".
- Por favor, tenga en cuenta que las fresas de metal duro integral son productos de un alto valor tecnológico. Es por ello que no podremos darle curso a un pedido de reafilado sin contar con todas las respuestas y aclaraciones solicitadas en este formulario.
- El revestimiento aplicado luego del reafilado (si el cliente lo solicita) será el mismo que el de las fresas estándar entregadas por Sin Par S.A.
- Tenga en cuenta que en el caso del reafilado de fresas la longitud útil de la fresa disminuye.
- Luego del afilado el diámetro estará escrito en cada caja para cada fresa.
- No se reafilan fresas con diámetros inferiores a 6,0mm

**MÁS LÍNEAS DE
PRODUCTOS SIN PAR**



INFINIT B400M
MÁQUINA DE SIERRA DE
CINTA SIN FIN

**SIERRAS
CIRCULARES**



**BITS Y CUCHILLAS
PARA TORNOS**



**INSERTOS Y
PORTAININSERTOS**



**CUCHILLOS Y
CHAIRAS**



**LAMAS Y
PORTALAMAS**



DESBARBADORES



SIN PAR®

SIN PAR S.A.
CONESA 10 (B1878KSB)
QUILMES - BS. AS. - ARGENTINA
VENTAS@SINPAR.COM.AR
WWW.SINPAR.COM.AR

TEL/ FAX BS. AS. +54 (11) 2152 0670
TEL/ FAX CÓRDOBA + 54 (0) 351 441 9599
TEL/ FAX ROSARIO + 54 (0) 341 465 6494
WHATSAPP: +54 (911) 6402-4937

